

LN2000 Hardware System

Table of contents

I. LN2000 System Hardware Installation 3

- 1 General..... 3
- 2 Cabinet Dimension and Installation 3
- 3 Arrangement of interiors inside the Process Control Cabinet 5
- 4 Arrangement of interiors inside the Relay Cabinet 6
- 5 System Power Distribution Plan 7
- 6 System Grounding Requirements 8

II. Process Control Station (LN-PU)..... 9

- 1 Hardware Structure..... 9
- 2 Main Functions..... 9
- 3 Operating Status 10
- 4 Features..... 11

III. LN-B Series Intelligent Module 13

- 1 General Purpose Section of Intelligent Module 13
- 2 LN-01B Isolated Analog Input Module 17
- 3 LN-02B Isolated Thermocouple Input Module 22
- 4 LN-03B Isolated RTD Input Module 26
- 5 LN-04B Isolated Pulse Input Module..... 30
- 6 LN-05B Isolated Analog Output Module 35
- 7 LN-06B Isolated Digital Input Module 38
- 8 LN-07B Isolated Digital Output Module..... 42
- 9 LN-09B Isolated SOE Module..... 48
- 10 LN-GPS Module 50

I. LN2000 System Hardware Installation

1 General

LN2000 system hardware are erected in the standard control cabinets. Apart from the process control stations and process control cabinets for I/O modules, these cabinets' covers also relay cabinets and system power distribution cabinets, etc. Normally, these cabinets have identical dimensions and same appearance. However, special types of cabinets can be ordered by the customer as per project requirements.

2 Cabinet Dimension and Installation

Dimension: 800 mm (W)× 600.mm (D) ×2260 mm (H)

Height includes:

Lifting lug: 30 mm
 Cabinet body: 2200 mm
 Base frame: 100 mm

Dimension of the cabinet is shown in Figure 1-1 and installation dimension is show in Figure 1-2.

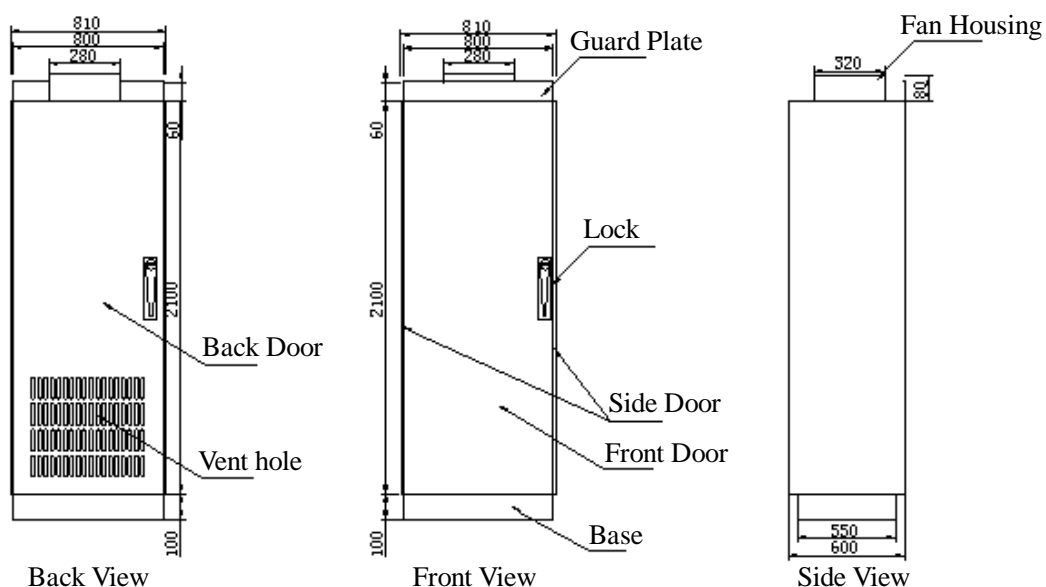

Figure1-1 Dimension of Cabinet

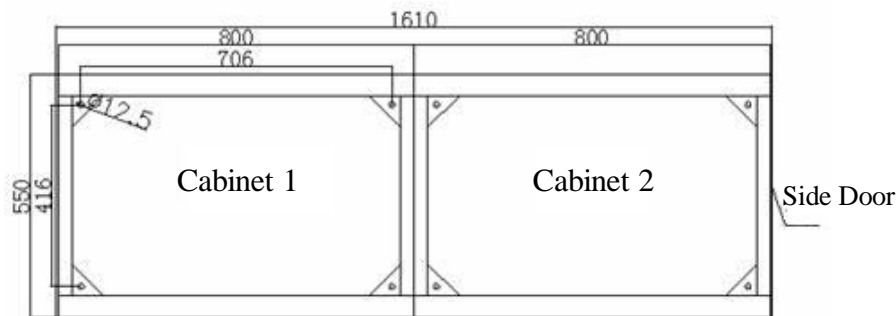

Figure1-2 Installation Dimension of cabinet

Cabinet doors are out-swinging type with a thickness of 20mm, and opened in right-hand mode. Two points (at upper part & lower part) on the door-hinge connect the door and the door frame. The door is fixed to the door frame by using a lock at the mid-point, with two pins at the opposite position of door and door frame for fixing the upper & lower sections of the cabinet door. Keys are uniform that means one key can open all locks. The cabinet door has a high tightness.

The side boards on both sides of a cabinet are also external hanging type with a thickness of 30mm. only side boards on the terminal end of cabinet train are required, and no side board is erected between cabinets. To avoid deformation of cabinet door and side boards, reinforcing ribs are provided.

Cabinets can be united by three large bolts (at upper, middle & lower portions) respectively on front and back sides.

Vent holes for convection are located on the front and back doors with filters. Grounding bolts are provided on the bottom part of front and back doors, and in the middle of front and back doors lies structure for connecting anti electrostatic ring.

A convection fan is installed on the top of cabinet (with an area of 160mm×160mm) supported by 220VAC power. A grating is equipped between cabinet top and the fan to prevent foreign matters from dropping in.

An area for fixing nameplates is left above both front door and back door.

Lifting lugs of the cabinet are installed on the middle of two sides with reinforcing ribs.

The base of a cabinet is a bracket with an area of 100mm ×50mm ×50mm. The base connects with the cabinet bottom with an isolating pad between them for isolation.

A square hole is made on the bottom of the cabinet for field cable connection. A copper grounding plate is fixed on the bottom of the back door and the copper plate is isolated from the base. There are 100 M4 threaded holes on the plate.

4 cross beams on each side of the cabinet are used for fixation and support.

3 Arrangement of interiors inside the Process Control Cabinet

A pair of redundant process control stations, a pair of redundant 24VDC supplies and 52 I/O modules or relay boards can be installed in a process control cabinet. The arrangement is as shown in Figure1-3.

Components in the cabinet from top to bottom are:

- Convection fan
- PU and power supply
- Exchanger
- I/O module

Natural cooling with air convection is adopted for cabinet cooling. The air comes in from the air inlet at the lower part of the back door and goes out by means of the fan from the top of cabinet.

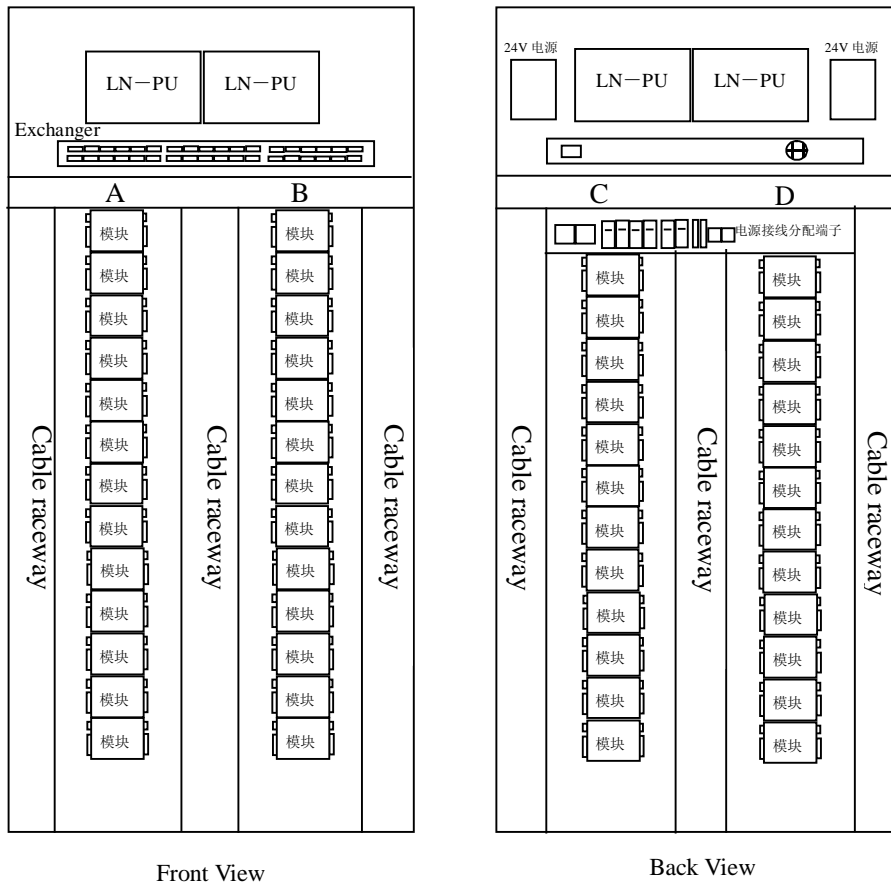

Figure1-3 Arrangement of interiors inside the process control cabinet

4 Arrangement of interiors inside the Relay Cabinet

A pair of redundant 24VDC supplies and 52 MY relay boards (26 large MK relay boards) can be installed in a relay cabinet. Relay boards and DO modules are connected via prefabricated cables. The arrangement is as shown in Figure1-4.

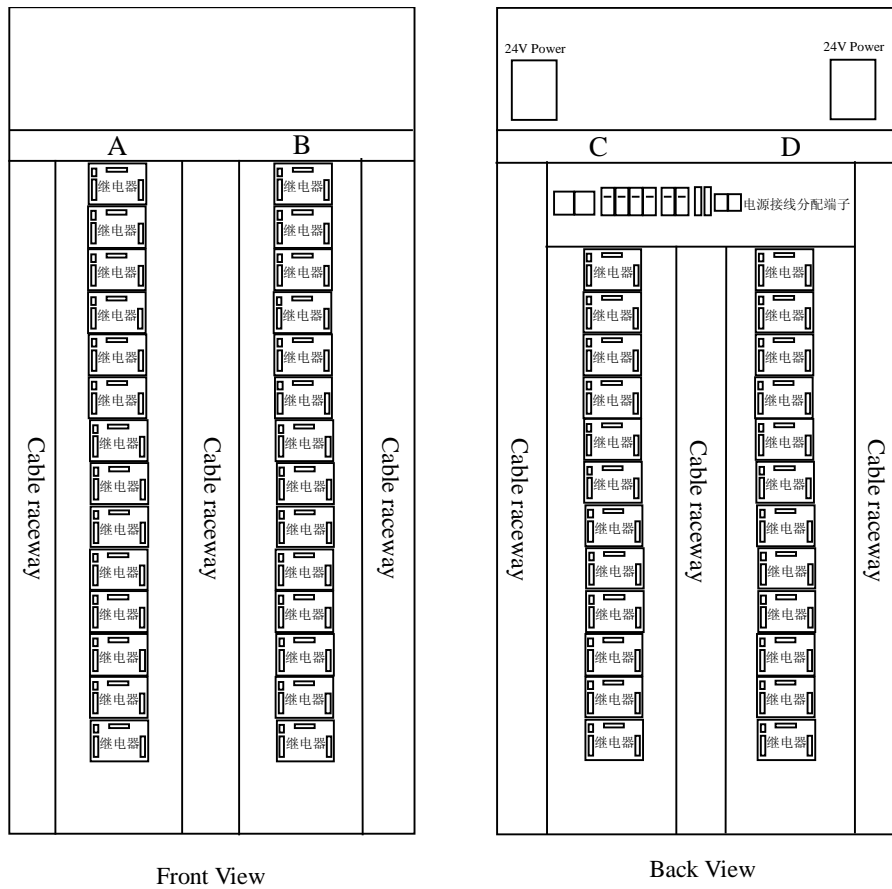

Figure1-4 Arrangement of interiors inside the Relay cabinet

5 System Power Distribution Plan

Dual service independent 220VAC supplies are required in the LN2000 system, which are distributed to individual cabinets through the distribution circuits inside the power distribution cabinet and used as power supplies of DC power modules and partial digital outputs. In case of one power failure, the system will switch over to the other to ensure normal operation and send power failure alarm for timely maintenance.

Requirements for system power supply:

Voltage: 220VAC $\pm 10\%$

Frequency: 50Hz ± 2 Hz

Sine waveform distortion factor: Sum of harmonic components is less than 5% of fundamental component.



The maximum amplitude value superposed on the Sinusoidal Waveform due to the transient voltage pulses and surge voltages should be less than 100V in a period less than tens of to hundreds of microseconds.

6 System Grounding Requirements

To ensure the normal operation of LN2000 system, the grounding design and installation should comply with the following principles:

- Only one grounding point is required in LN2000 system;
- The resistance of the grounding copper plate to earth should be no more than 4Ω , it is better to be less than 1Ω ;
- The cabinet and the channel steel for fixing cabinet base must be insulated;
- The grounding system should not be connected to the grounding point of the high voltage equipment;
- The other equipment shall not be grounded via the LN 2000 grounding system.

II. Process Control Station (LN-PU)

The process control station (LN-PU) is a computer used for receiving the configuration messages downloaded from the engineer station, collecting I/O module data, performing control strategies and controlling production processes via I/O modules.

1 Hardware Structure

The process control station, as the most important part in the process control cabinet, is composed of the following system bus board, CPU main board, dual CAN interfaces card, power supply, housing and indicators. The CPU board is equipped with an embedded low power consuming CPU, 64M RAM, 32M E-disc (DOM) and dual 100M Ethernet ports and dual CAN interface card. The CAN maximum Baud Rate is 1M bps.

Power Supply: 220VAC, 0.5A

The appearance of the process control station is as shown in Figure 2-1.



Figure2-1 Appearance of Process Control Station

2 Main Functions

A real-time Multi-task operating system is applied in the LN-PU. The applications are embedded special control software, which is independently developed by the company. Its main tasks are to:

- Receive and perform the control strategies downloaded from the engineer station;
- Receive data collected by the I/O modules;

- Send commands and data to the I/O modules;
- Receive commands from the operator station;
- Send real-time data to the upper stations;
- Realize automatic and redundant back-up.

The application software and downloaded control strategies are stored in the E-disc so that no configuration data will miss in case of a power failure. The process control stations are arranged redundantly. The redundancy of the real-time data transmission and the stations is achieved by the built-in dual Ethernet ports redundant for each other. The redundant LN-PU automatically tracking the LN-PU in operation will seamlessly take over the process control tasks in case of a failure of the active station, with bumpless transfer/changeover.

The two CAN controllers on the LN-PU, which has complete redundancy capacity, communicate with intelligent I/O modules in a master-slave method and achieve the management of the I/O modules.

3 Operating Status

The arrangement of the process control station is redundant. Each station may be in the following status: initial status, master control operating status, partly tracking status, completely tracking status and offline status. The station in master control operating status is called the master station, while that in tracking status is called the standby station. The operating status of a station can be clearly indicated by the indicator on the station panel or by the self-diagnostic application.

- **Initial Status:** means no configuration file of control strategies in the LN-PU. If there is no configuration file downloaded in the LN-PU, the LN-PU will enter the initial status after a power up and then the configuration file can be downloaded. After that, the LN-PU will enter the master control operating status if no control station detected, otherwise it will change to partly tracking status.
- **Master Control Operation Status:** in this status, the station collects data from I/O modules, implements control strategies and controls the production process via I/O modules as well as sends real-time data to the upper stations and back-up data to the tracking station.



- **Partly Tracking Status:** during the normal operation of the master station, the later initiated station will enter the partly tracking status, i.e. the configuration files of master station are probably not identical with that of the standby station. In this status, online downloading is acceptable.
- **Completely Tracking Status:** during the normal operation of the master station, the later initiated station will enter the partly tracking status. When the configuration files of control strategies have been copied from the master station to the standby station, the standby station will enter the completely tracking status. In this status, online downloading is acceptable. After online downloading, if the configuration files of the master station and the standby station are not identical, the standby station will change over to the partly tracking status. If a changeover is done between the master and standby station, the control strategies on-line downloaded will be performed.
- **Offline Status:** the power on for the LN-PU is unavailable or a failure occurred.

4 Features

- A low power consuming CPU is adopted for the control station without needing any fan for cooling, greatly extending its service life and improving its stability as well as providing hardware warranty for the system reliability.
- The hardware watchdog is utilized for the process control station, realizing the progress level supervisory control and conquering the problem of casual lock-up.
- An originally developed technique is incorporated in the data broadcasting system, with dual networks broadcasting simultaneously, thus achieving balanced control of data flow and avoiding the network broadcasting “storm” effect.
- Back-up of process station is carried out by two redundant networks, avoiding the disadvantages of a single back-up by a third-party network or by parallel cables.
- The communication between the process control station and I/O modules is realized by the CAN field bus with redundant arrangement, which enhances the system reliability.



The process control station can be on-line or off-line configured and on-line downloaded after the configuration. By this way, the system availability is warranted and the time for system operation and maintenance is saved so that a convenient way is provided for site commissioning and installation as well as for the user to be familiar with the system.

III. LN-B Series Intelligent Module

1 General Purpose Section of Intelligent Module

(1) General

The LN-B series intelligent I/O modules for the field bus are the latest products developed by our company. Its performance, reliability and accessibility are much higher than similar products and it can be widely used in electric power, petrochemical, metallurgy and light industries. Its main features are:

- High-performance and low power consuming 16-bit chip microprocessor;
- Fully independent and isolated dual CAN field bus interfaces;
- Two 24 VDC supplies;
- Two-level hardware watchdogs and offline recovery function;
- Self sustaining output signals in case of system fault or being reset;
- Channel-channel isolation of analog input/output signals;
- Jumper-selected internal/external supply for analog input signals, supporting the two-wire system transmitter;
- The Sequence of Events (SOE) module is equipped with three independent CAN interfaces with high accuracy of synchronization between modules, and the SOE resolution is less than 1 millisecond;
- ETS protection module includes SOE function, and the protection function is performed through hardware circuit;
- Modules can be installed remotely, Transmission distance: 3.3km/20kbps, 620m/100kbps, 270m/250kbps, 130m /500kbps;
- GPS module with dual CAN interface and RS232/485 port providing standard time.
- Protection for modules and self-recovery of communication channels, two-level overcurrent protection;
- Independent power and CAN communication terminals isolated from signal terminals;



- Field power cables which can be directly connected to hot-plug terminal boards without intermediate transfer
- Four panel indicators (for power, operation, CAN-A status and CAN-B status);
- Complete industry-class components are adopted with an operating temperature range of -10°C -60°C;
- Dimension: 120mm (W) × 112mm (H) × 48mm (D), horizontally installed;
- Metal casing.

The software for the LN intelligent modules is hardened in the 16-bit chip processor with high system stability. The watchdog function ensures that the system will have self-recovery capability. The communication mode rests with the CAN field bus. 63 intelligent modules at the most can be linked to the field bus via the protocol of CAN2.0A. The intelligent modules exchange data with the process control stations in an interval configured by the customer.

(2) Setting of Module Address and Baud Rate

Module address and Baud Rate are set through the thumb wheel switch (SW1) in the module. The Baud Rate depends on transmission distance (the relation between Baud rate and distance is shown in Table 3-1). The Maximum Baud rate of CAN communication is up to 1Mbit/s. normally, the provided Baud rates set through thumb wheel switches are in four levels: 20K, 100K, 1000K and 500K. If these four Baud rates can not satisfy the needs, modification request can be proposed according to the actual communication distance while planning orders.

Table 3-1 Baud Rate and communication distance

BIT RATE(BPS)	1M	500K	250K	125K	100K	50K	20K	10K	5K
Max. length	40m	130m	270m	530m	620m	1.3Km	3.3Km	6.7Km	10Km

Note: The above is only for reference. Which have something to do with the crystal lattice and diameter of communication cable in the process of actual use. To ensure reliable communication, relatively low Baud rate is

normally preferred.

The setting of thumb wheel switch SW1 is as follows: bit 1~6 of SW1 are address setting switches while bit 6 is the highest bit while bit 1 is the lowest. The valid addresses of the module are 1~63 and the addresses must be set in this range by customer before use. In case any switch is turned to position "ON", the relative bit is set as "0" and when the switch is turned to "OFF" the bit will be "1". In Figure3-1, the values on the right side of "a" are decimal "0" when all bits are in position "1". The address value of a module is the sum of 6 hex values set by thumb wheel switches. E.g. Thumb wheel switch b refers to address: 26, and thumb wheel switch c refers to address: 44.

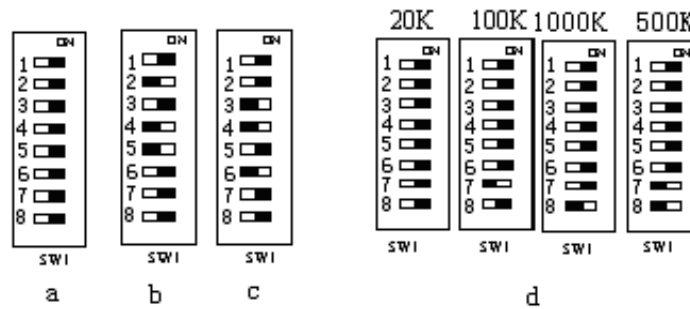

Figure3-1 Setting of thumb wheel switch SW1

The setting of module Baud rate: bit 7~8 of thumb wheel switch SW1 are the switches for setting Baud rate. Baud rate is normally ex-works set in four levels: 500K, 1000K, 100K and 20K (special requirements should be specified when placing orders). The relationship between thumb wheel switch position and Baud rate is shown in Figure3-1.

(3) Dimension and Operating Temperature of Modules

Dimension: 120mm×110mm×40mm(L×W×D)
 Operating temperature: -10℃~60℃ -25℃~60℃(special order)
 Storage temperature: -25℃~ +85℃
 Humidity: 90% (without dew formation)

(4) Indicators and Terminal lugs

The appearance of a module is as shown in Figure3-2. For more details, please refer to Table 3-2.

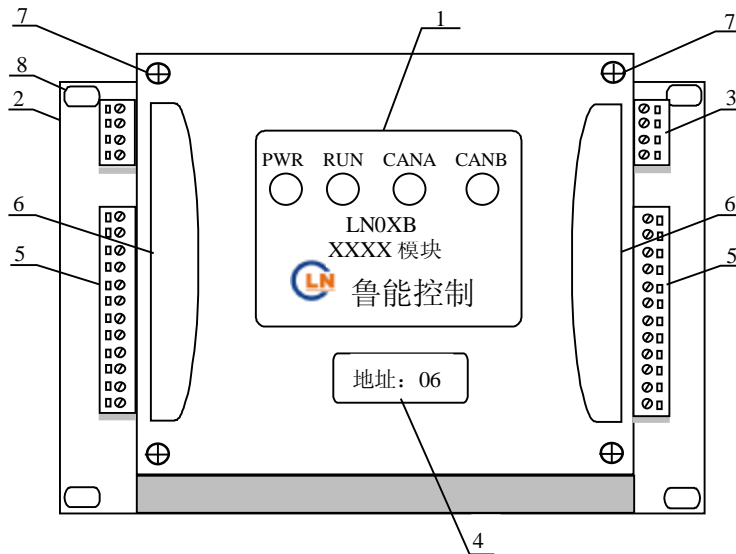

Figure3-2 Appearance of a module

Table 3-2 Indicators and Wiring Terminals

<p>1. INDICATOR (BOARD)</p>	<p>Four LED indicators on the panel: a single red, a single green and two double-color (red and green) indicators.</p> <p>From left to right, respectively being the indicators of power (PWR), running (RUN), CANA and CANB.</p> <p>The single red LED is power (PWR) indicator; the green one is running (RUN) indicator; blinking green LED means the module in normal operation.</p> <p>The double-color LEDs are communication indicators classified as indication of CANA and CANB and respectively indicating the operating status of CAN network A and network B.</p> <p>Red light of the double-color LED means normal sending status and green means normal receiving status.</p> <p>Blinking of red and green lights of the double LEDs means that the module is in normal sending and receiving status.</p> <p>The blinking of two red lights of the double-color LEDs at the same time means that the watchdog is in reset status or abnormal communication status. Alternate blinking of two green lights of the double-color LEDs means that the module is in such a status that the type is not matched.</p>
-----------------------------	--



2. Dual-channel 24 VDC Wiring Terminal	Dual +24VDC±10% power supply. A redundant 24VDC power supply is available for the module.
3. Double CAN Wiring Terminals	Two independent CAN bus interfaces redundant for data transmission.
4. Address IDENTIFICATION	Indicates the address number of a module in the control cabinet defined by the thumb wheel switches.
5. Terminal Board	Wiring is carried out as per the wiring tags (item 6).
6. Terminal Wiring Tag	Indicates the definition of individual wiring terminals.
7. Panel Fixation holes	Located on the four corners of a module panel.
8. Auxiliary Fixation Plate and bolt holes	The ellipse fixing holes are located on the auxiliary plate for securing the module to the cabinet rail.

2 LN-01B Isolated Analog Input Module

(1) Principle

The LN-01B isolated analog input module has 8 input channels which are separately electrically isolated. An A/D converter with 12 bit resolution is adopted. When LN-01B works, the input voltage or current signals will pass through input terminals, disconnecter, low pass filter, instrument amplifier and A/D converter, and then be sent to a singlechip via optoelectronic isolator. The singlechip computer is used to collect data and perform software filter, and communicate with process control station (LN-PU) via CAN communication interface.

There are two power feeding methods for LN-01B measurement circuit: internal and external power feedings. The external method means that active analog input signals can be provided at the transducer side, while the internal method means that the LN01-B module provides 24V power for the transducer.

The block diagram of LN-01B module is as shown in Figure3-3.

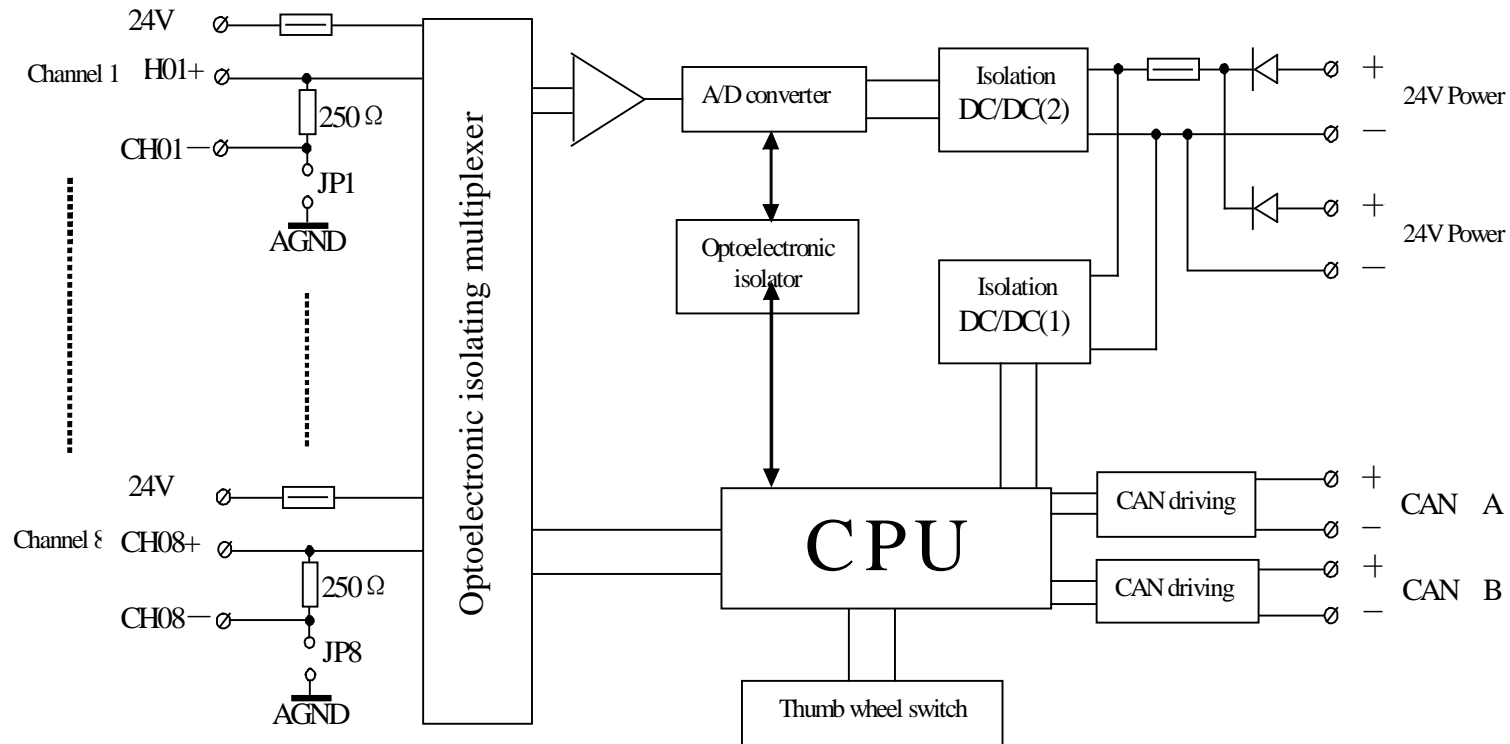

Figure3-3 Principle block diagram for LN-01B isolated analog input module

(2) Main Technical Parameters

Module Type		LN-01B
Input Channel	Number of Channels	8 channels with double ends input, isolated from each other
	Signal type	4~20mA /0~10mA
	Measurement accuracy	0.1%
	Current input impedance	250Ω
	Voltage input impedance	>2MΩ
	Input processing	Low pass filter, over-current and over-voltage protection
	Common-mode rejection	>130dB
	Difference-mode rejection	>60dB
	Isolation voltage between channels	1000Vrms
	Internal/external power feeding	Selectable by jumper, supporting two-wire system transducer
	Conversion rate	10 times/ second for all channels
communication	Number of Interfaces	2 channels, redundant for each other
	Baud Rate	500kbps/1000kbps/100kbps/20kbps
Power Supply	Power Redundancy	2, redundant for each other
	Voltage	24VDC00B110%
	Power isolating voltage	1000VDC
	Power(MAX)	3W external power for all channels /7W external power for all channels
Other	A quick-breaking general fuse is provided	
	An overcurrent self-recovery fuse is provided for each channel.	
	The module address is set by the DIP thumb wheel switch	
	Operating temperature: -10℃~60℃	

(3) Main Components Arrangement

LN-01B isolated analog input module 's main component arrangement (shown in Figure3-4) :

FUSE: Changeable power fuse
 SW: CAN Communication address and Baud Rate setting switch
 PWR: Power LED indicator
 RUN: Operation LED indicator

- CANA: CAN A Communication LED indicator
- CANB: CAN B Communication LED indicator
- JP1~JP8: Internal/external power feeding jumper setting for CH01(channel 1)to CH08(channel 8)

Definition of Wiring Terminals:

- 24V1+, 24V2+: Module power supply (DC24V) positive pole
- 24V1-, 24V2-: Module power supply (DC24V) negative pole
- CANA+: CAN A Communication signal positive end
- CANA-: CAN A Communication signal negative end
- CANB+: CAN B Communication signal positive end
- CANB-: CAN B Communication signal negative end
- CH01+~CH08+: Analog input channel1~8 signal positive end
- CH01-~CH08-: Analog input channel1~8 signal negative end

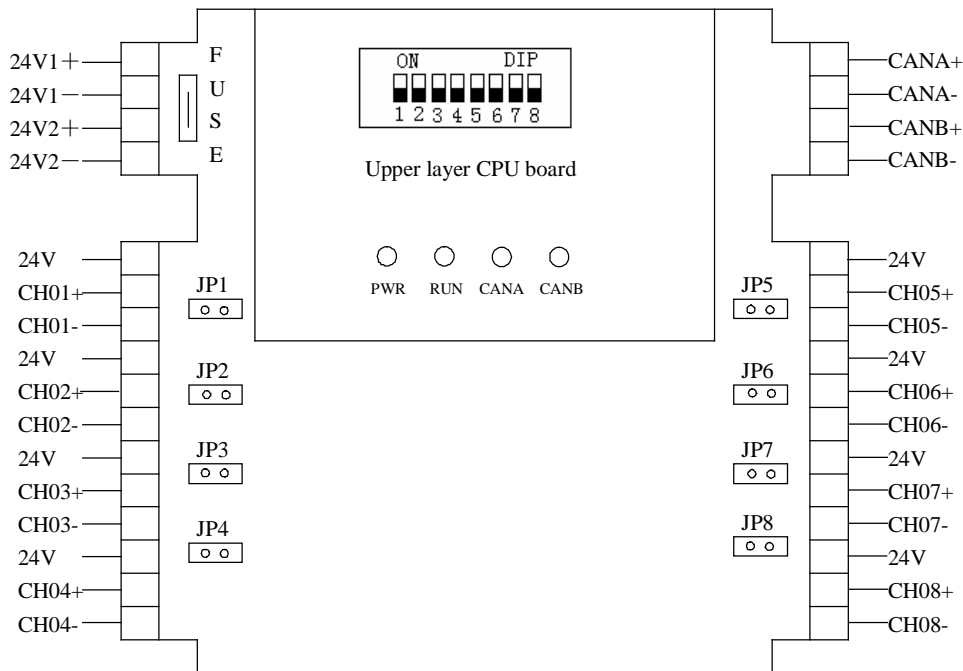

Figure 3-4 LN-01B main component arrangement and definition of wiring module terminals

(4) Wiring Method

Internal/ external power feeding method can be independently set for each of 8 channels analog inputs of LN-01B module. Each channel (CH01~CH08) has a corresponding jumper (JP1~JP8). When a channel is set as external power feeding method, the relative jumpers (JP) will open & "+" and "-" will be used as channel input. When internal power feeding method is set for a channel, relative jumpers will be connected and "24V" and "+" will be used as channel input. For more details refer to the following figure:

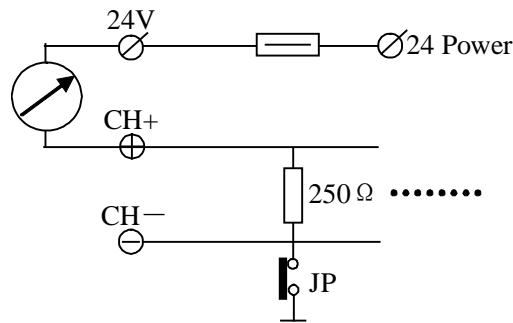

Figure3-5 Wiring for internal power feeding method

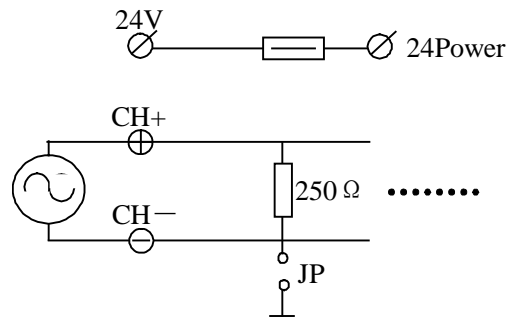

Figure3-6 Wiring for external power feeding method

3 LN-02B Isolated Thermocouple Input Module

(1) Principle

8 thermocouple input channels are provided for LN02B isolated intelligent thermocouple input module together with an A/D converter with 24 bit resolution. The module is equipped with in-house multiplexer, programmable amplifier, digital filter and accuracy adjustment function, which can effectively restrain power frequency interference and attain high accuracy measurement results. When module works, the input thermocouple or millivolt signal will pass through input low pass filter, A/D converter and optoelectronic isolator, and then be sent to the singlechip computer. The singlechip computer is used to collect data and perform software filter, and communicate with process control station (LN-PU) via CAN communication interface.

Varieties of standard or nonstandard thermocouples can be connected to the module. The thermocouple graduation number of each channel can be modified via upper software and each channel has an independent graduation number.

An auto cold junction temperature compensation circuit is provided with the module realizing internal temperature compensation. A thermocouple broken alarm function is also provided.

The principle of the module is as shown in Figure3-7.

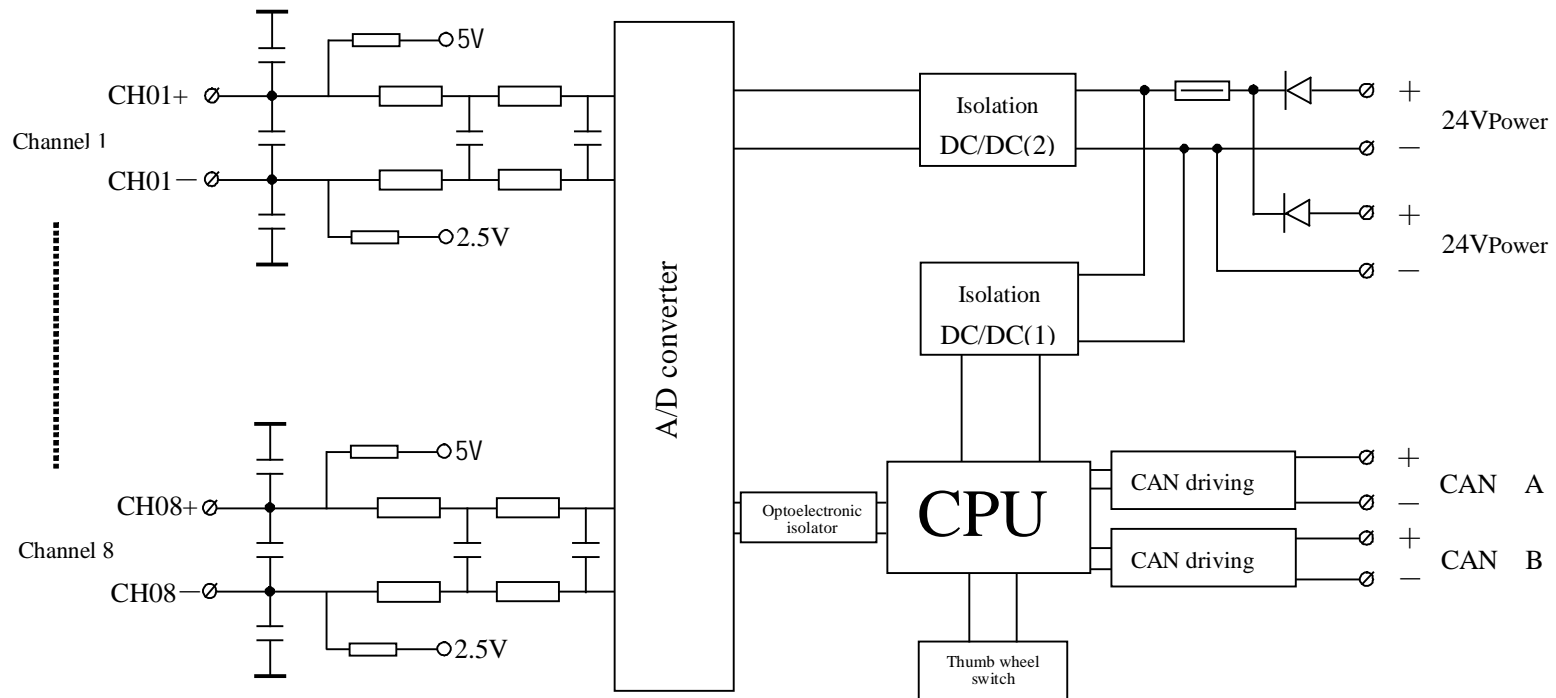

Figure3-7 Principle block diagram of LN-02B isolated thermocouple input module

(2) Main Technical Parameters

	Module Type	LN-02B
Input Channel	Number of channel	8 channels with double ends input
	Signal type	Thermocouple B, J, K, T, E, R, S and N mV (nonstandard)
	Graduation number selection	Supporting online graduation number modification of each channel
	Measurement Accuracy	0.1%
	Cold junction compensation	Connecting with cold junction compensating component
	Linearization	Automatically performed internally
	Line-broken alarm	Yes
	Input impedance	>2MΩ
	Common-mode rejection	>130dB
	Difference-mode rejection	>70dB
	Conversion rate	1 time/ second for all channels
Communication	Number of interfaces quantity	2, redundant for each other
	Baud Rate	500kbps/1000kbps/100kbps/20kbps
Power Supply	Power supply Redundancy	2, redundant for each other
	Voltage	24VDC±10%
	Power isolating voltage	1000VDC
	Power(MAX)	3W
Others	A quick-breaking general fuse is provided	
	Module address and Baud rate are set by DIP thumb wheel switches	
	Operating temperature: -10℃~60℃	

(3) Main Component Arrangement

LN-02B isolated intelligent thermocouple input module's main component arrangement (shown in Figure3-8)

FUSE: Changeable power fuse
 SW: CAN Communication address and Baud Rate setting switch
 PWR: Power LED indicator
 RUN: Operation LED indicator
 CANA: CAN A Communication LED indicator
 CANB: CAN B Communication LED indicator

Definition of Wiring Terminals:

24V1+, 24V2+:	Module power supply (DC24V) positive end
24V1-, 24V2-:	Module power supply (DC24V) negative end
CANA+:	CAN A Communication positive end
CANA-:	CAN A Communication negative end
CANB+:	CAN B Communication positive end
CANB-:	CAN B Communication negative end
CH01+~CH08+:	Thermocouple input positive end
CH01-~CH08-:	Thermocouple input negative end
NC:	N.A.
T01~T03:	Connecting with cold junction compensating component externally

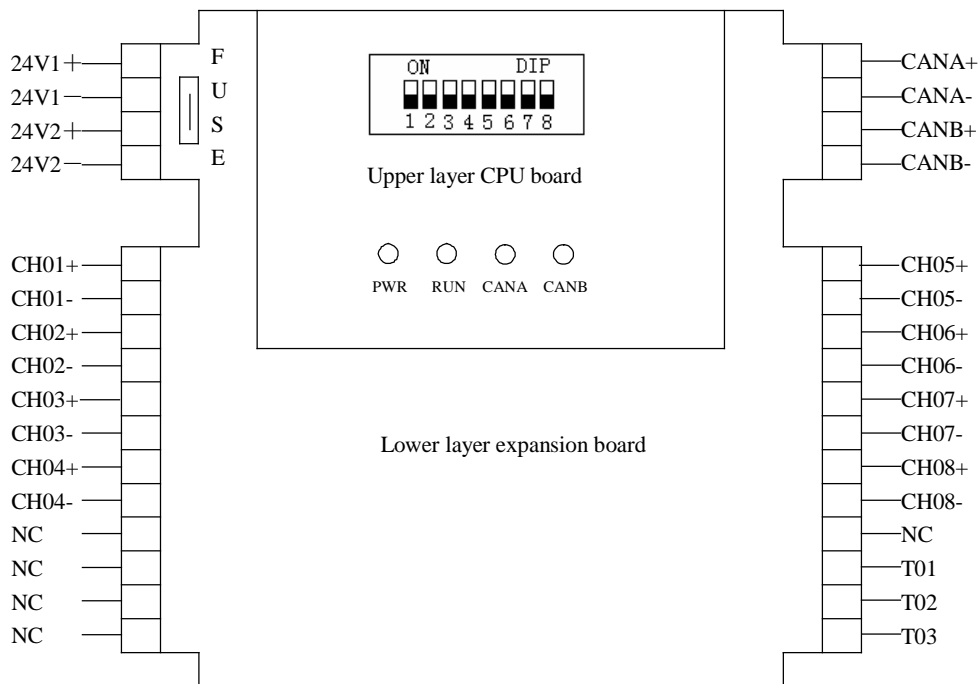

Figure3-8 LN-02B main components arrangement and definition of wiring terminals

(4) Wiring Method

LN02 thermocouple input module has 4 input channels. Taking single channel as example, the wiring method is described in Figure 3-9.

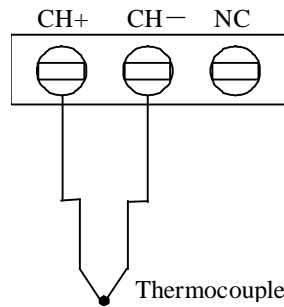

Figure 3-9 LN02B module 1 channel connection schematic diagram

4 LN-03B Isolated RTD Input Module

(1) Principle

8 thermocouple input channels are provided for LN-03B isolated intelligent RTD input module together with an A/D converter with 24 bit resolution. A high accuracy A/D converter is adopted for the module equipped with built-in multiplexer, programmable amplifier, digital filter and accuracy adjustment function, which can effectively restrain 50Hz power frequency interference and attain high accuracy A/D converted results. When the module works, a voltage signal created by the RTD (activated by a constant current source) which is connected to the input terminals will be sent to the single-chip computer via the optoelectronic isolator after processed by low pass filter and A/D converter. Under the control of the singlechip computer, the A/D converted result will be transmitted via CAN communication interface to upper computer for displaying and processing.

Varieties of standard or nonstandard thermocouples can be connected to the module. The thermocouple graduation number of each channel can be modified via upper software and each channel has an independent graduation number.

3-wire system wiring method is adopted for the RTD input wiring, avoiding the interference caused by line resistance. Meanwhile, it can provide a line-broken alarm function.

The logic block diagram of LN-03B is as shown in Figure3-10.

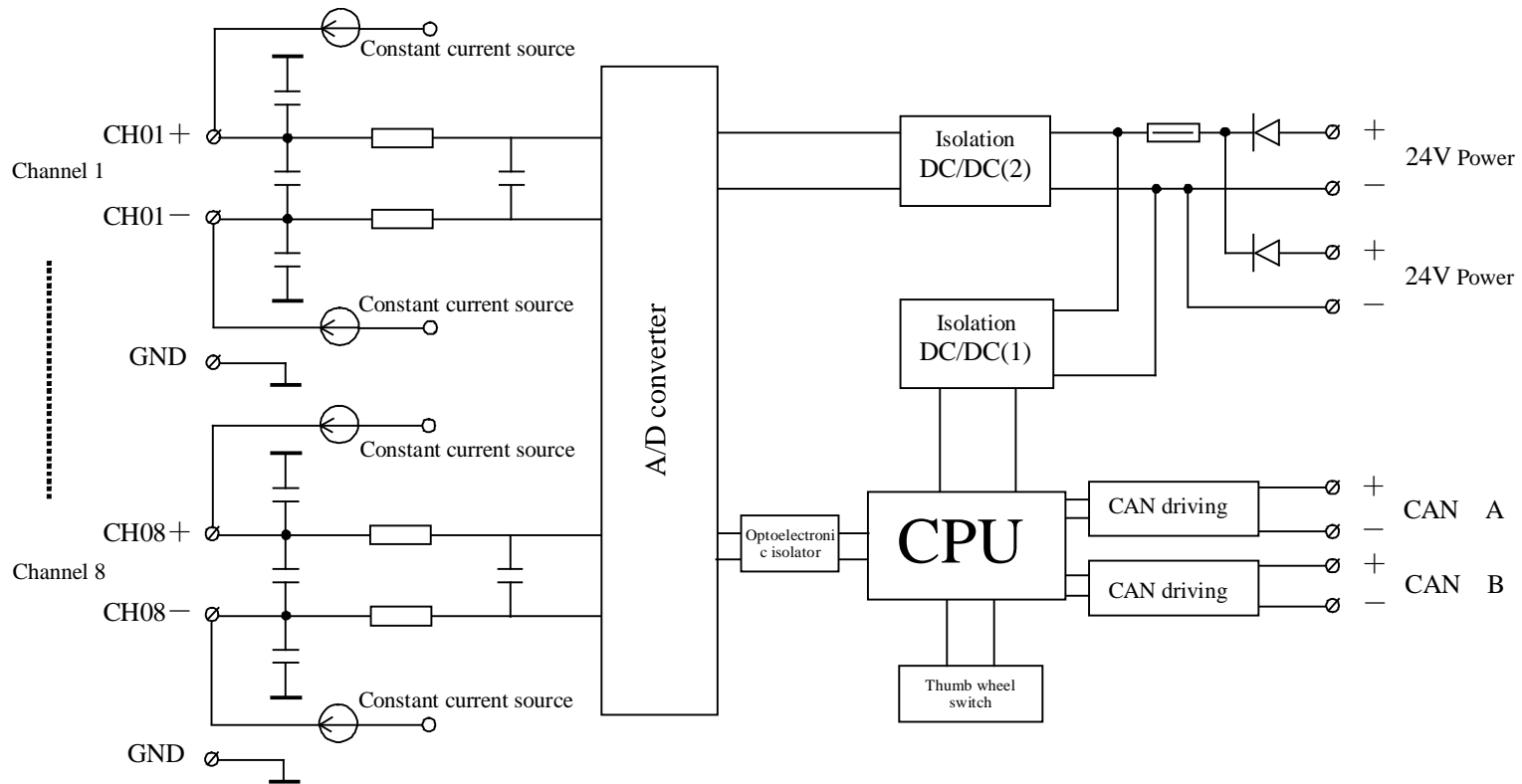

Figure3-10 Principle block diagram of LN-03B isolated RTD input module

(2) Main Technical Parameter

Module Type		LN-03B
Input Channel	Number of channel quantity	8 channels with 3-wire system input
	Signal type	Rtd Pt50, Pt100, Cu50, Cu100Ω (nonstandard)
	Graduation number selection	Supporting online graduation number modification of each channel
	Measurement Accuracy	±0.1%
	Input method	Driven by an accurate constant current source
	linearization	Automatically performed internally
	Line-broken alarm	Yes
	Input impedance	>2MΩ
	Common-mode rejection	>130dB
	Difference-mode rejection	>70dB
	Conversion rate	1 time/ second for all channels
Communication	Number of Interface	2, redundant for each other
	Baud Rate	500kbps/1000kbps/100kbps/20kbps
Power Supply	Power Supply Redundancy	Dual redundancy
	Voltage	24VDC±10%
	Power isolating voltage	1000VDC
	Power(MAX)	3W
Others	A quick-breaking general fuse is provided	
	Module address and Baud rate are set by DIP thumb wheel switches	
	Operating temperature:-10℃~60℃	

(3) Main Components Arrangement

LN-03B isolated intelligent thermocouple input module main component arrangement is as shown in Figure3-11.

FUSE: Changeable power fuse
 SW: CAN Communication address and Baud Rate setting switch
 PWR: Power LED indicator
 RUN: Operation LED indicator
 CANA: CANA Communication LED indicator
 CANB: CANB Communication LED indicator

Definition of wiring terminals:

24V1+, 24V2+:	Module power supply (DC24V) positive end
24V1-, 24V2-:	Module power supply (DC24V) negative end
CANA+:	CAN A Communication positive end
CANA-:	CAN A Communication negative end
CANB+:	CAN B Communication positive end
CANB-:	CAN B Communication negative end
CH01+~CH08+:	RTD input positive end
CH01-~CH08-:	RTD input negative end
GND:	Input single ground

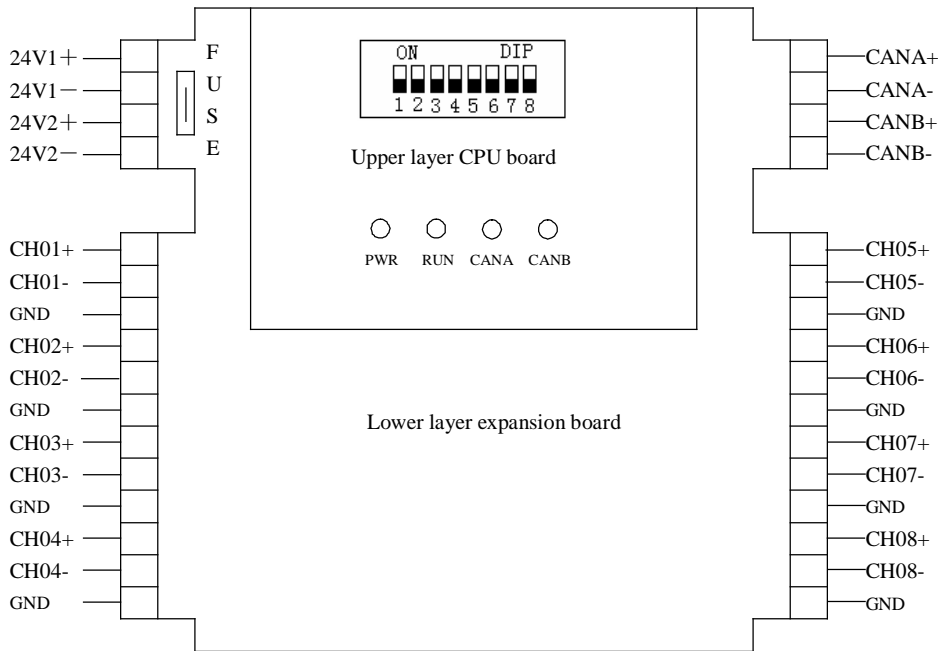

Figure3-11 Main component arrangement of LN-03B and definition of module wiring terminal

(4) RTD Wiring Method

LN-03B RTD input module has 8 input channels. The wiring method of 3-wire system is as shown in Figure3-12 (taking channel 1 as example).

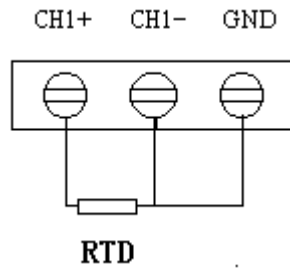

Figure3-12 Schematic diagram of RTD 3-wire system wiring method

5 LN-04B Isolated Pulse Input Module

(1) Principle

4 input channels are provided for LN-04B isolated pulse input module, which can be used for measuring speed of rotating equipment, power consumption of electric consumers and accumulated coal consumption. There are two working methods for each channel: pulse frequency measurement and accumulated value measurement and the methods can be selected by jumper. Under pulse frequency measurement method, identical accuracy measurement method is adopted with a measurement range of 0.001~10 kHz. Under accumulated value measurement method, input pulses are counted with an accumulated value up to 4,294,967,295.

Input method: Eddy current probe, pulse method, sine and square wave methods are applicable.

When the module works, the input pulse signals will be sent to a singlechip computer via the optoelectronic isolator after being processed. Under the control of the singlechip computer, the measured values will be transmitted to process control station via CAN communication interface.

LN-04B principle block diagram is as shown in Figure3-13.

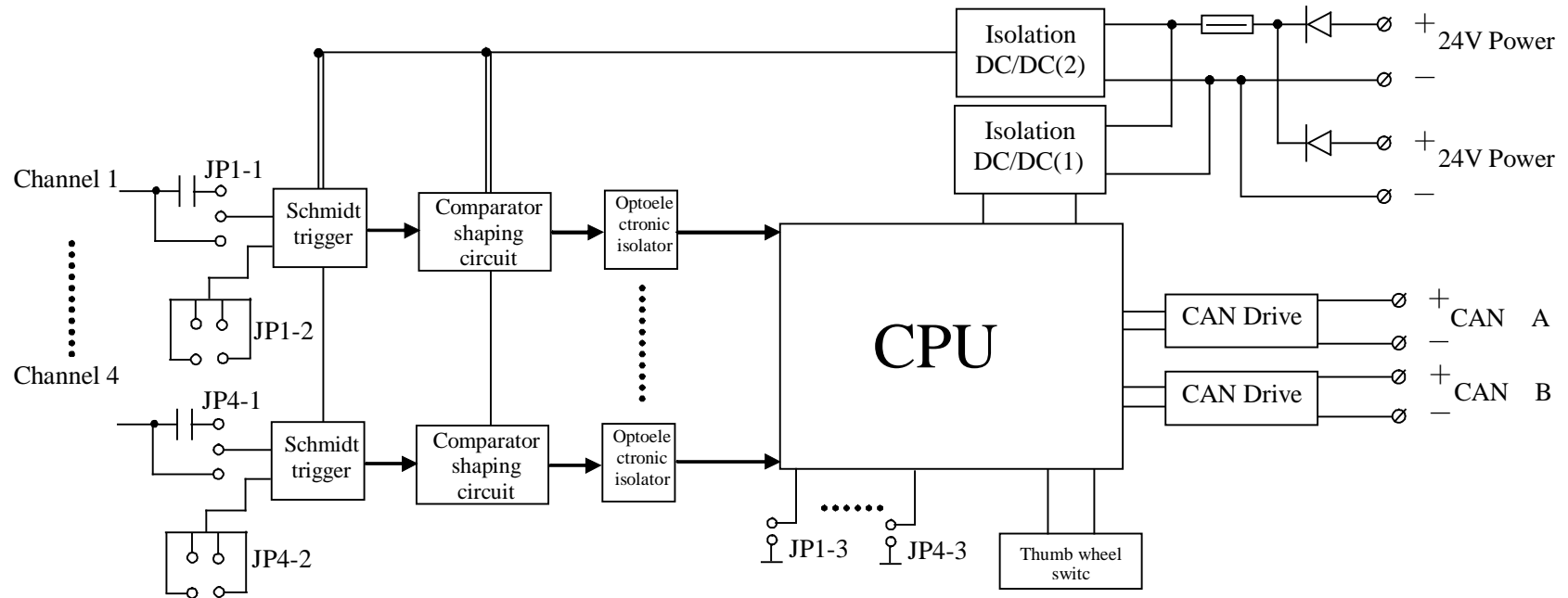

Figure3-13 Principle block diagram of LN-04B isolated pulse input module

**(2) Main Technical Parameter**

Module Type	LN-04B	
Input Channel	Number of channel quantity	4 channels
	Measurement range	0.001~10kHz
	Signal type	1~24V AC or pulse signal (dc signals can be superposed and triggering threshold can be selected)
	Measurement accuracy	Frequency error less than the measured result * 0.001Hz/ counter±1
	Internal /external power feeding	Selectable
	Detecting rate	1 time/ second for all channels (for low speed pulse, once per cycle)
Communication	Number of Interface	2, redundant for each other
	Baud Rate	500kbps/1000kbps/100kbps/20kbps
Power Supply	Power supply Redundancy	2, redundant for each other
	Voltage	24VDC±10%
	Power isolating voltage	1000VDC
	Power (MAX)	3W
Jumper	One set of jumper is used for selecting input signal type (AC/DC).	
	One set of jumper is used for selecting triggering threshold of the Schmidt trigger inside the module.	
	One set of jumper is used for selecting measurement type(frequency / accumulated value).	
Others	A quick-breaking general fuse is provided.	
	The module address is set by the DIP thumb wheel switch.	
	For signal of each channel, it can be cleared during measurement of accumulated value.	
	Operating temperature: -10℃~60℃.	

(3) Main Component Arrangement

Main component arrangement of LN-04B isolated pulse input counter module (shown in Figure3-14).

FUSE: Changeable power fuse
 SW CAN Communication address and Baud Rate setting switch
 PWR Power LED indicator

RUN:	Operation LED indicator
CANA	CANA Communication LED indicator
CANB	CANB Communication LED indicator

Definition of wiring terminals

24V1+, 24V2+:	Module power supply (DC24V) positive end
24V1-, 24V2-:	Module power supply (DC24V) negative end
CANA+:	CAN A Communication positive end
CANA-:	CAN A Communication negative end
CANB+:	CAN B Communication positive end
CANB-:	CAN B Communication negative end
24V:	For supply of power to sensor
CH01+~CH04+:	PI input positive end
CH01-~CH04-:	PI input negative end
Z01+~Z04+:	1~4 channel clear (signal) positive end
Z01-~Z04-:	1~4 channel clear (signal) negative end
NC:	N.A.

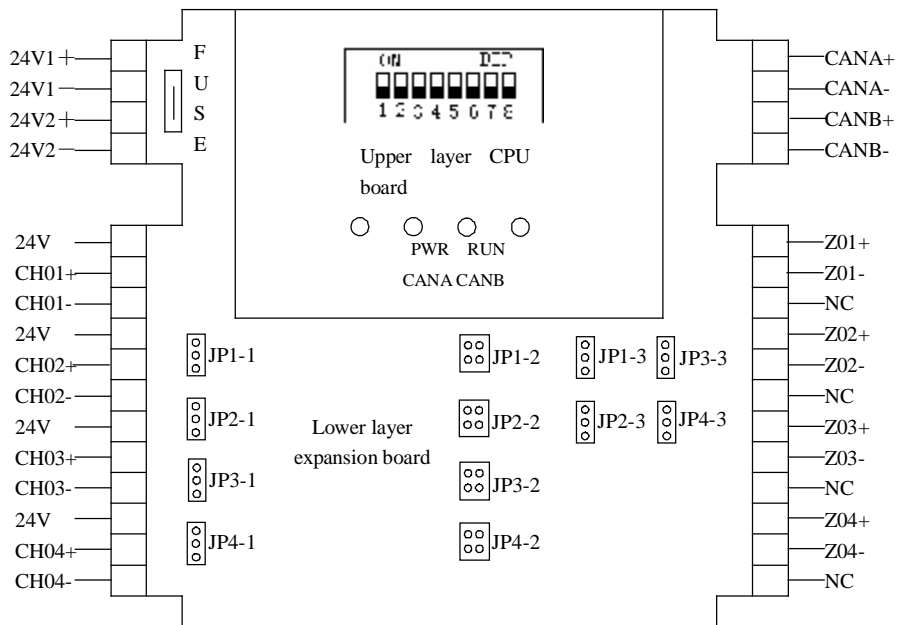

Figure 3-14 LN05B Main component arrangement and definition of module wiring terminals

(4) Setting of Input Signal Measurement Method

When module LN04 is used for measurement of rotating speed signal, three jumper wiring methods are provided, which are set as per the following.

Jumper JPX-1 is used for selecting input signal type AC or DC.

The methods for selection of this channel via short-circuit strip to bridge AC or DC is as shown in the following figure:

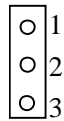

DC: 1 and 2 directly connected; AC: 2 and 3 directly connected

Jumper JPX-2 is used for selection of triggering threshold of the Schmidt trigger inside the module.

The setting method for the lagging voltage of the Schmidt trigger is as shown in the Figure3-15.

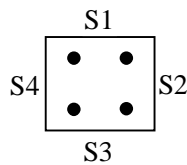
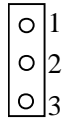

Figure 3-15 Setting of lagging voltage

- S1~S4 all broken: symmetrical lagging, voltage: $0V \pm 0.3V$
- S1 short-circuited: asymmetrical lagging, voltage: $-0.25 \pm 0.3V$
- S2 short-circuited: asymmetrical lagging, voltage: $-1.15 \pm 0.3V$
- S3 short-circuited: asymmetrical lagging, voltage: $+1.15 \pm 0.3V$
- S4 short-circuited: asymmetrical lagging, voltage: $+0.25 \pm 0.3V$

Jumper JPX-3 is used for selection of measurement type e.g. frequency or accumulated value.

The measurement type (frequency or accumulated value) is selected by the jumper, the short-circuited measurement value refers to the accumulated value and the non-short-circuited measurement value refers to that of frequency signal for measuring frequency signal.



Pulse method: 1 and 2 directly connected; Accumulated value method: 2 and 3 directly connected.

6 LN-05B Isolated Analog Output Module

(1) Principle

4 analog output channels are provided for LN-05B isolated analog output module. Channels are separately isolated and also isolated from the singlechip computer. 4~20mA current signals are output and no additional isolator is needed. When module LN05B works, output data are transmitted to the singlechip computer via CAN Communication interface and sent to D/A converter after being processed by the optoelectronic isolator. The output signal type can be selected as voltage or current signal by the jumper. In case of communication failure, the output remains unchanged.

Module principle is as shown in Figure3-16.

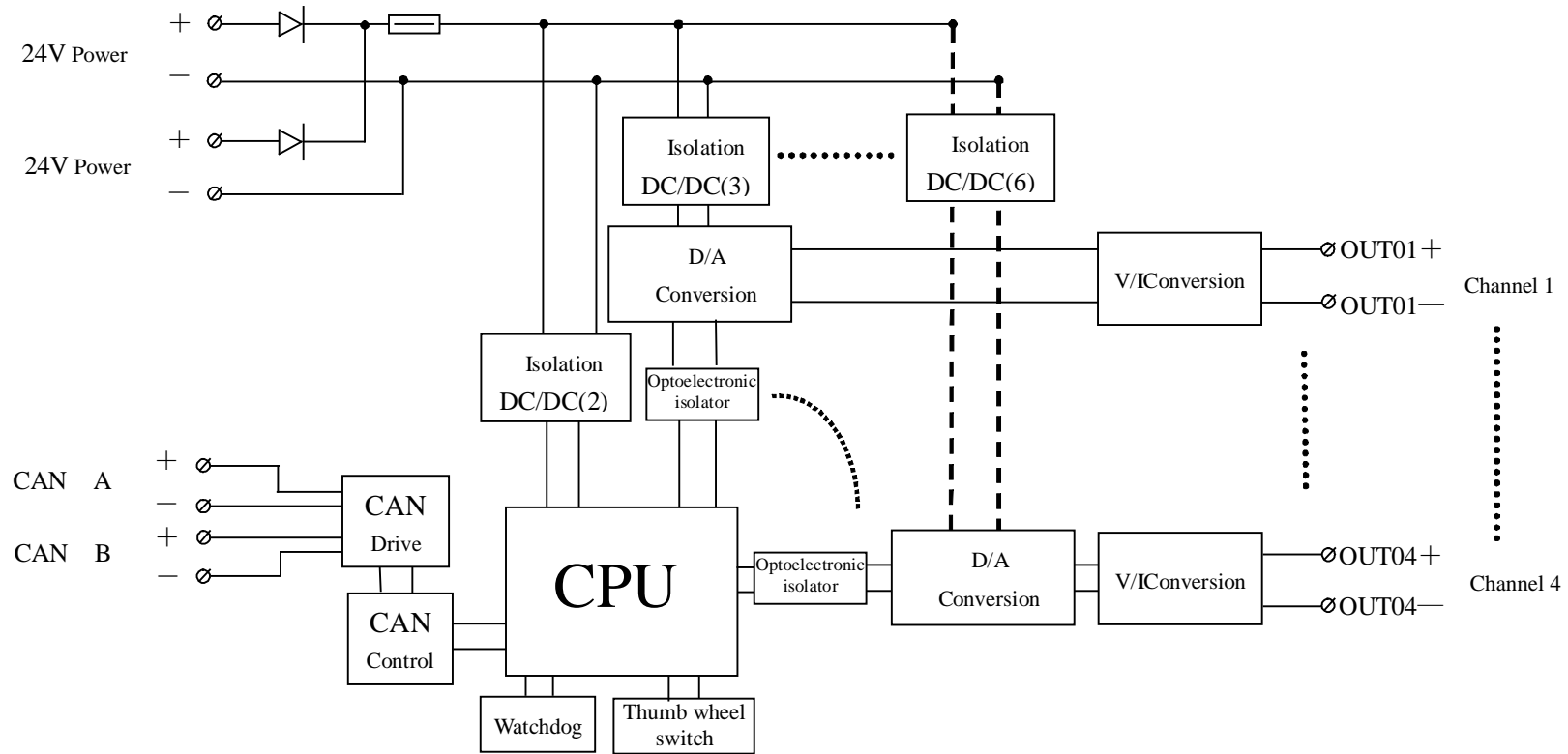

Figure3-16 Principle block diagram of LN-05B isolated analog input module

**(2) Main Technical Parameters**

MODULE TYPE		LN-05B
Output Channel	Number of channel quantity	4 channels, separately isolated
	Signal type	4~20mA / 0~10mA/ 1~5V/ 0~10V
	Output Accuracy	0.1%
	Load capability	Max. 500Ω
Communication	Number of Interface	2, redundant for each other
	Baud Rate	500kbps/1000kbps/100kbps/20kbps
Power Supply	Power supply Redundancy	2, redundant for each other
	Voltage	24VDC±10%
	Power isolating voltage	1000VDC
	Power(MAX)	5W
Others	A quick-breaking general fuse is provided	
	The module address is set by the DIP thumb wheel switches	
	Operating temperature: -10℃~60℃	

(3) Main Component Arrangement

Main component arrangement of LN05B isolated analog output module (shown in Figure 3-17).

FUSE:	Changeable power fuse
SW:	CAN Communication address and Baud Rate setting switch
PWR:	Power LED indicator
RUN:	Operation LED indicator
CANA:	CAN A Communication LED indicator
CANB:	CAN B Communication LED indicator
W1~W4:	output signal full scale adjusting POT
XF1~XF4:	selectable jumper for output voltage (short-circuited) or current (not short-circuited) of OUT1~OUT4

Definition of wiring terminals:

24V1+, 24V2+:	Module power supply (DC24V) positive end
24V1-, 24V2-:	Module power supply (DC24V) negative end
CANA+:	CAN A Communication positive end
CANA-:	CAN A Communication negative end

CANB+:	CAN B Communication positive end
CANB-:	CAN B Communication negative end
OUT1+~OUT4+:	Output signal positive end
OUT1-~OUT4-:	Output signal negative end
NC:	N.A.

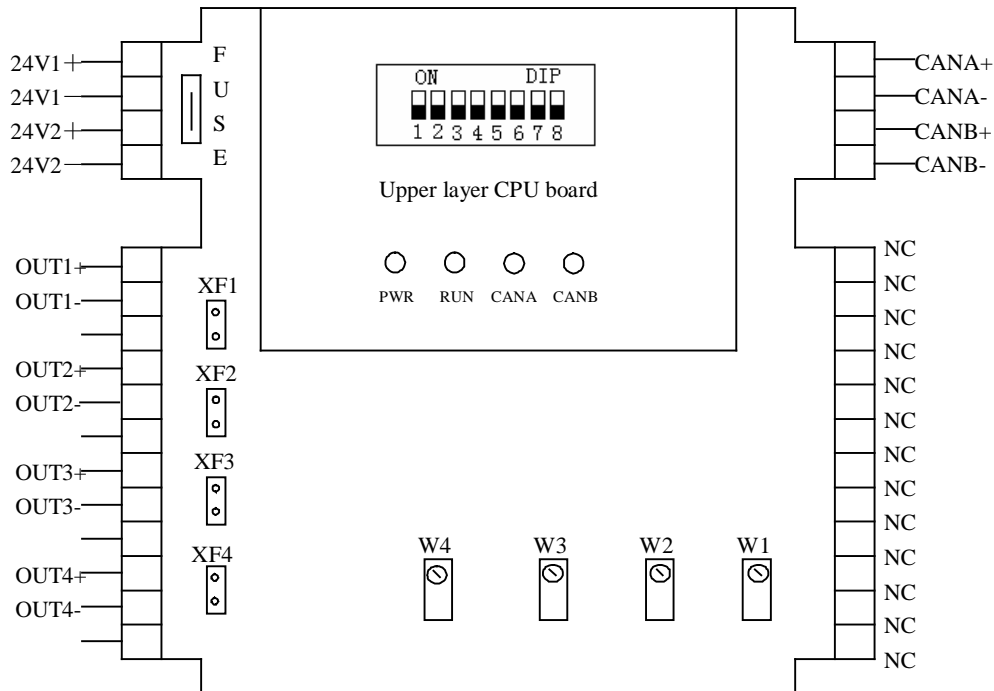

Figure3-17 LN05main component arrangement

7 LN-06B Isolated Digital Input Module

(1) Principle

12 digital input channels are provided for LN06B isolated digital input module. When the module works, inactive contact signals are transmitted to the singlechip computer via the optoelectronic isolator after being processed at the signal input end. Under the control of the singlechip computer, digital status input signals are sent to the upper computer via the CAN communication interface.

Logic block diagram of module LN06B is as shown in Figure3-18.

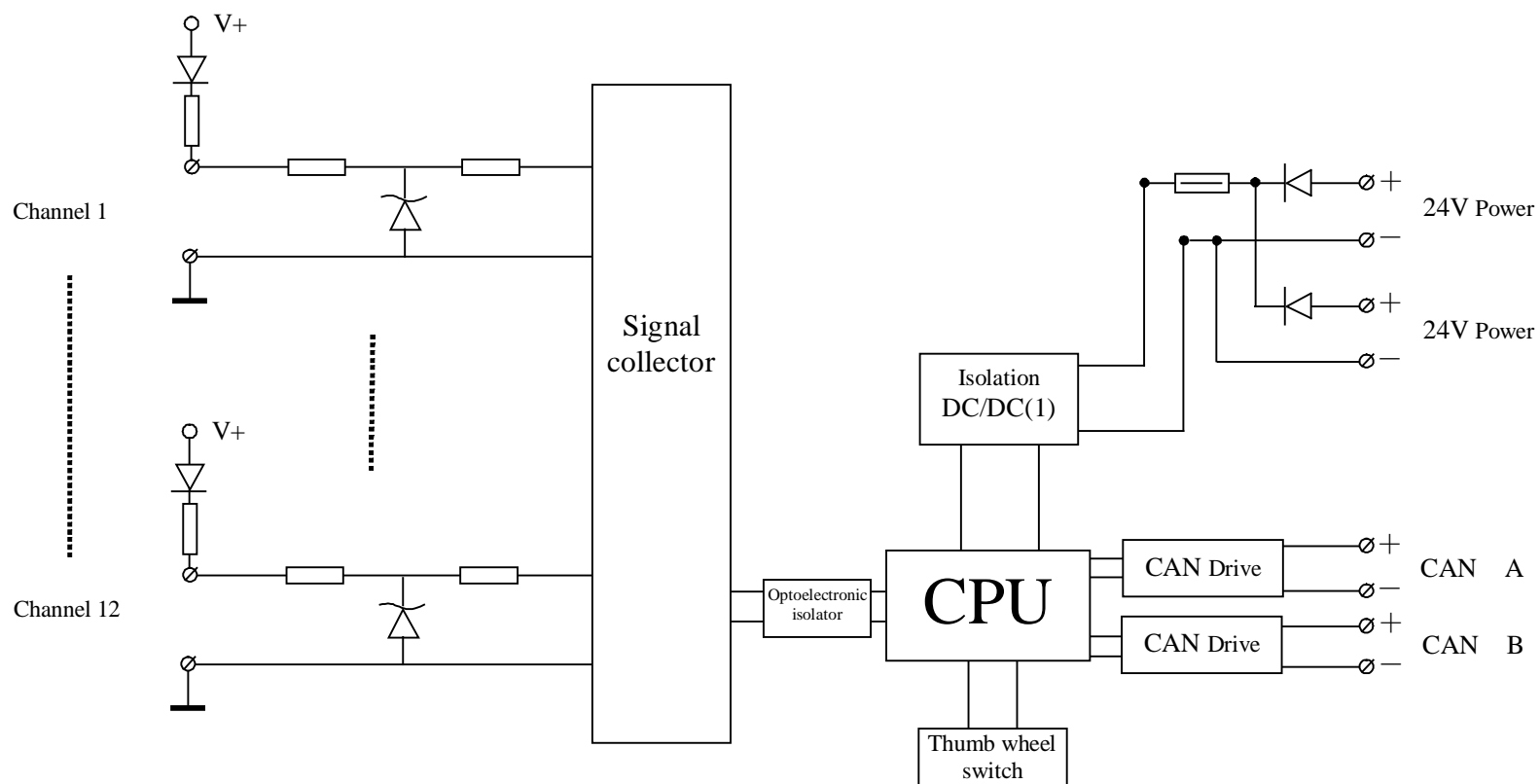

Figure3-18 Principle block diagram of LN06B isolated digital input module

(2) Main Technical Parameter

	Module Type	LN-06B
Input Channel	Number of Channel	12 channels
	Signal type	Dry contact
	Logic '0' level	>20V
	Logic '1' level	<15V
	Dithering eliminating time	20ms
	Scanning period	<2ms
	System isolation voltage	1000Vrms
Communication	Number of interface	2, redundant for each other
	Baud Rate	500kbps/1000kbps/100kbps/20kbps
Power Supply	Power supply Redundancy	2, redundant for each other
	Voltage	24VDC±10%
	Power isolating voltage	1000VDC
	Power(MAX)	4W
Other	A quick-breaking general fuse is provided	
	The module address is set by the DIP thumb wheel switches.	
	Operating temperature: -10℃~60℃	

(3) Main Component Arrangement

Main component arrangement of LN06B isolated digital input module (shown in Figure 3-19):

- FUSE: Changeable power fuse
- SW1: CAN Communication address and Baud Rate setting switch
- PWR: Power LED indicator
- RUN: Operation LED indicator
- CANA: CAN Communication LED indicator
- CANB: CANB Communication LED indicator
- SW2: CANC/CH12 switch jumper (it is digital input mode when SW2 jumpers 3 and 5, 4 and 6 are connected; it is SOE mode when SW2 jumper 1 and 3, 2 and 4 are connected). Details are to be given LN09B description.

Definition of wiring terminals

24V1+, 24V2+:	Module power supply (DC24V) positive end
24V1-, 24V2-:	Module power supply (DC24V) negative end
CANA+:	to CANA Communication positive end
CANA-:	to CANA Communication negative end
CANB+:	to CANB Communication positive end
CANB-:	to CANB Communication negative end
CH01+~CH12+:	to digital input channel1~12signal positive end
CH01-~CH12-:	to digital input channel1~12signal negative end

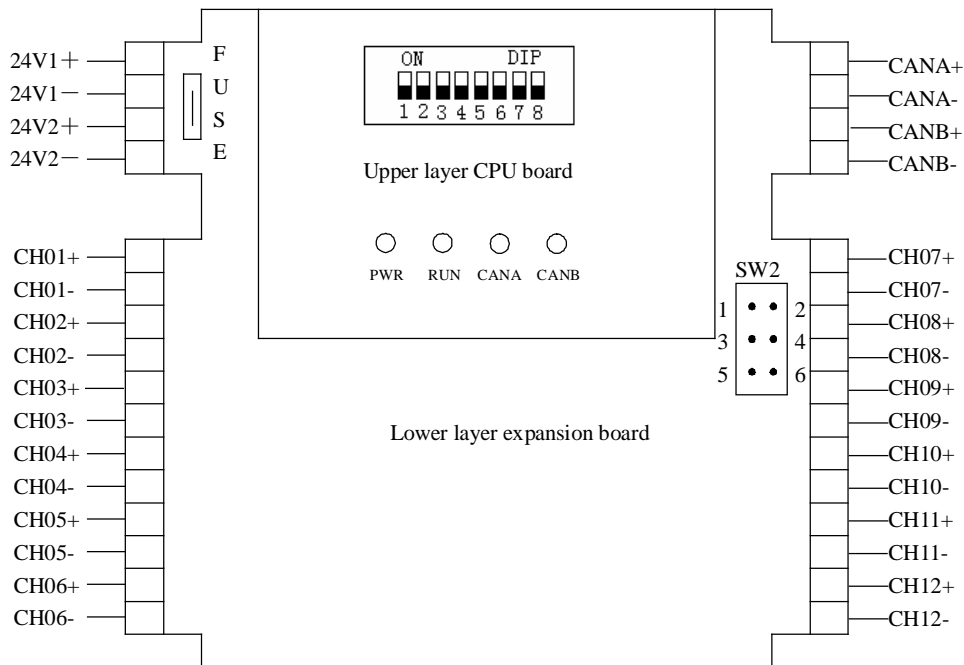
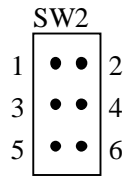

Figure3-19 LN06B main component arrangement

(4) Jumper Selection

A set of jumper (SW2) in the module LN-06B is used to select module function.

It appears as digital input function when SW2 jumpers 3 and 5, 4 and 6 are connected respectively when SW2 jumper 1 and 3, 2 and 4 are connected respectively it appears as SOE function. Description of SOE module is shown in the relative section of LN-09B.



(5) Signal Cable Wiring

Detailed wiring of signal cables is as shown in Figure3-20 (taking channel 1 as an example).

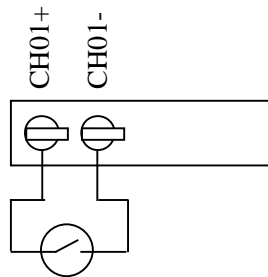

Figure3-20 Wiring for digital input signal

8 LN-07B Isolated Digital Output Module

(1) Principle

LN-07B isolated digital output module is provided with 16 output channels, which is an isolated intelligent digital output module possessing CAN field bus communication function.

When module LN-07B works, the output data are sent to the single chip computer via CAN field bus communication interface and output via optical MOS relay.

(2) Logic Block Diagram

Logic block diagram of LN07B isolated digital output module is as shown in Figure3-21.

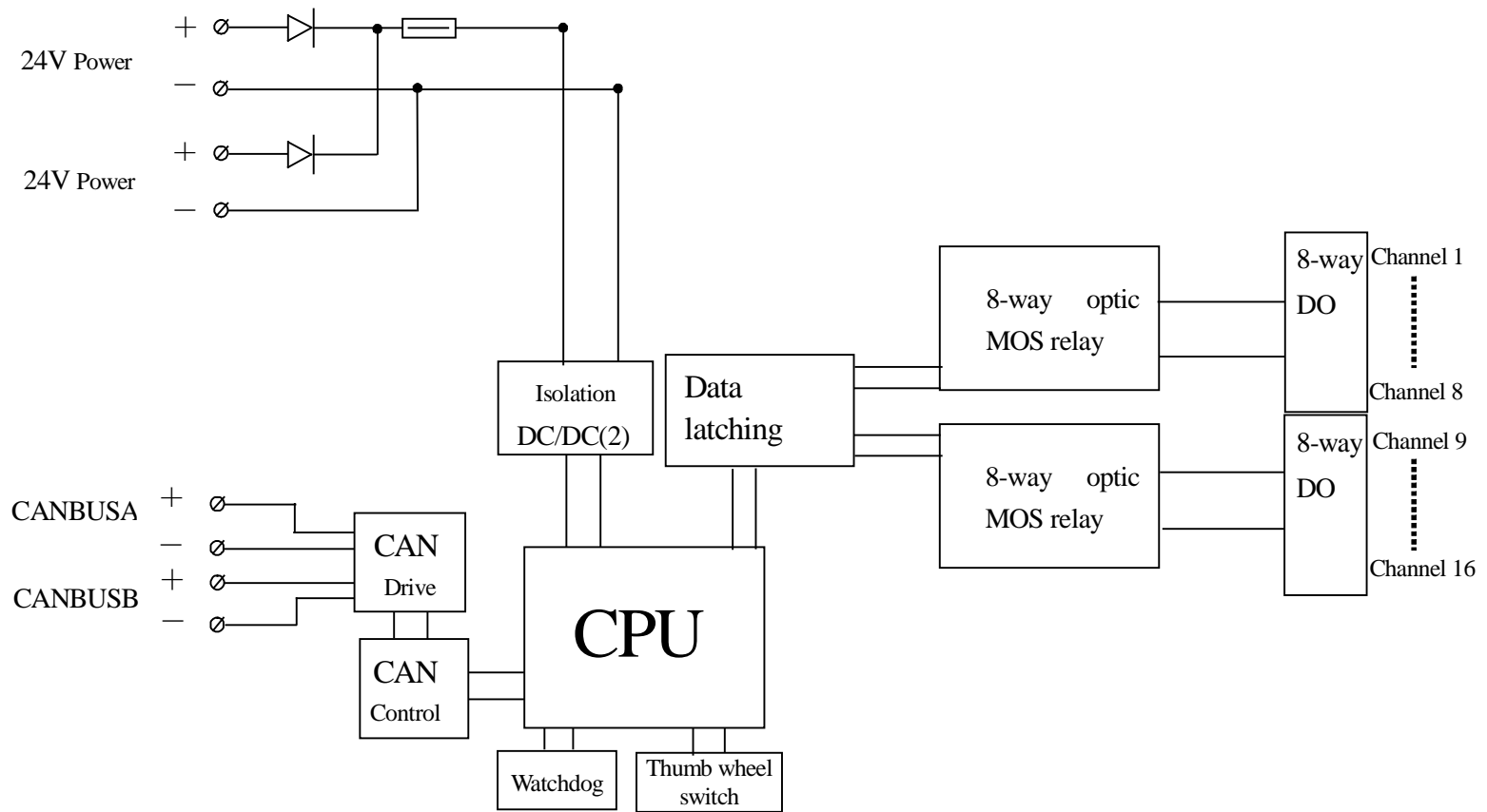

Figure 3-21 Principle block diagram of LN07B isolated digital output module

(3) Main Technical Parameters

	Module Type	LN-07B
Output Channel	Number of channel quantity	16 channels
	Output type	Optical MOS relay
	Output wiring method	Prefabricated cable
	Max. load voltage	60V DC
	Max. load current	400mA
	On-resistance(MAX)	0.7Ω
	Scanning time	<50ms
	Isolating voltage	1500VAC
Communication	Number of interface	2, redundant for each other
	Baud Rate	500kbps/1000kbps/100kbps/20kbps
Power Supply	Power Supply Redundancy	2, redundant for each other
	Voltage	24VDC±10%
	Power isolating voltage	1000VDC
	Power(MAX)	3W
Others	A quick-breaking general fuse is provided	
	The module address is set by the DIP thumb wheel switches	
	Operating temperature: -10℃~60℃	

(4) Main Component Arrangement

Main component arrangement of LN07B isolated digital output module (shown in Figure3-22)

D1, D2:	36P output socket for prefabricated cable
FUSE:	Changeable power fuse
SW1:	CAN Communication address and Baud Rate setting switch
PWR:	Power LED indicator
RUN:	Operation LED indicator
CANA:	CAN A Communication LED indicator
CANB:	CAN B Communication LED indicator

Definition of wiring terminals is as shown in Figure 3-23

24V1+, 24V2+:	Module power supply (DC24V) positive end
24V1-, 24V2-:	Module power supply (DC24V) negative end
CANA+:	to CANA Communication positive end

- CANA-: to CANA Communication negative end
- CANB+: to CANB Communication positive end
- CANB-: to CANB Communication negative end
- 36P socket D1: Channel 1-8 optical MOS relay output
- 36P socket D2: Channel 9-16 optical MOS relay output

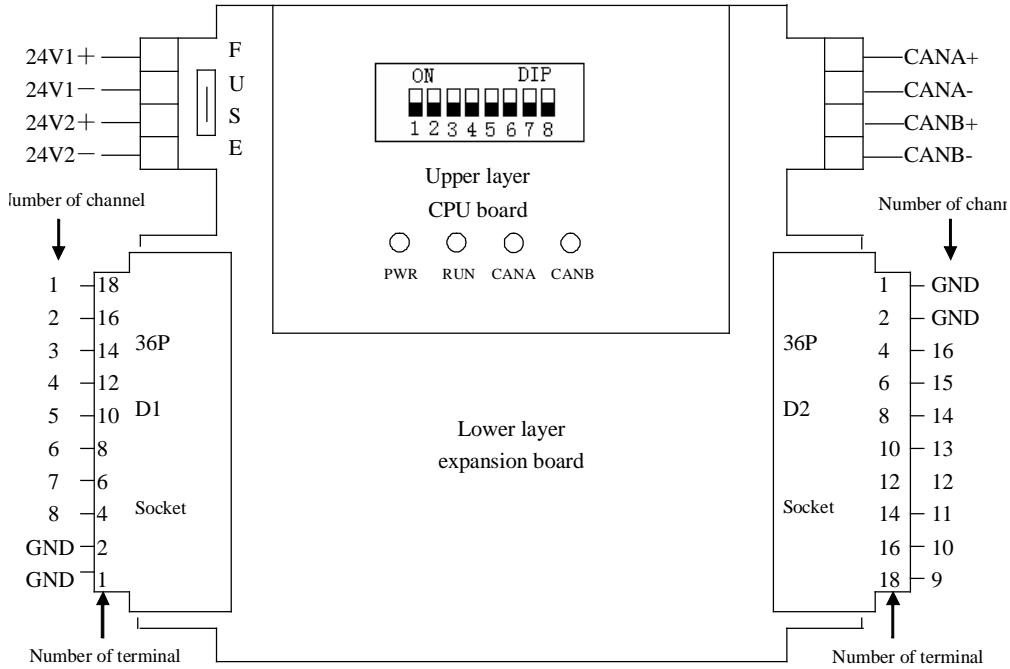

Figure3-22 Main component arrangement of LN07 module

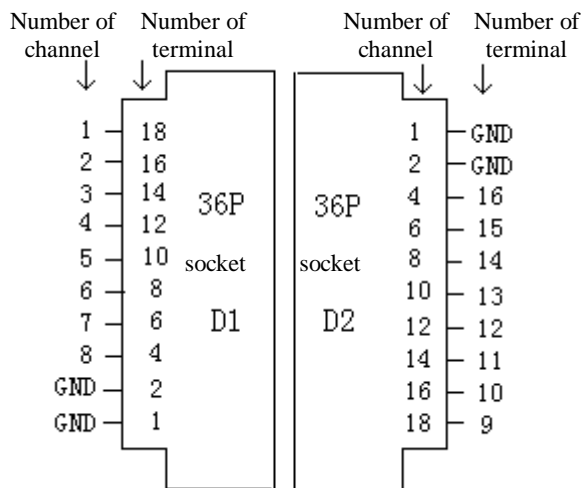

Figure 3-23 Definition of LN07B module wiring terminals

(5) Digital Output Board

LN07B digital output board can be use together with relay board LN-JDQ produced by our company. Both boards are connected by prefabricated cables, being able to directly control the output relay.

The relay boards can be classified into two categories according to output node capacity as shown in Figure3-24 and Figure3-25. The two kinds of board have the same wiring method.

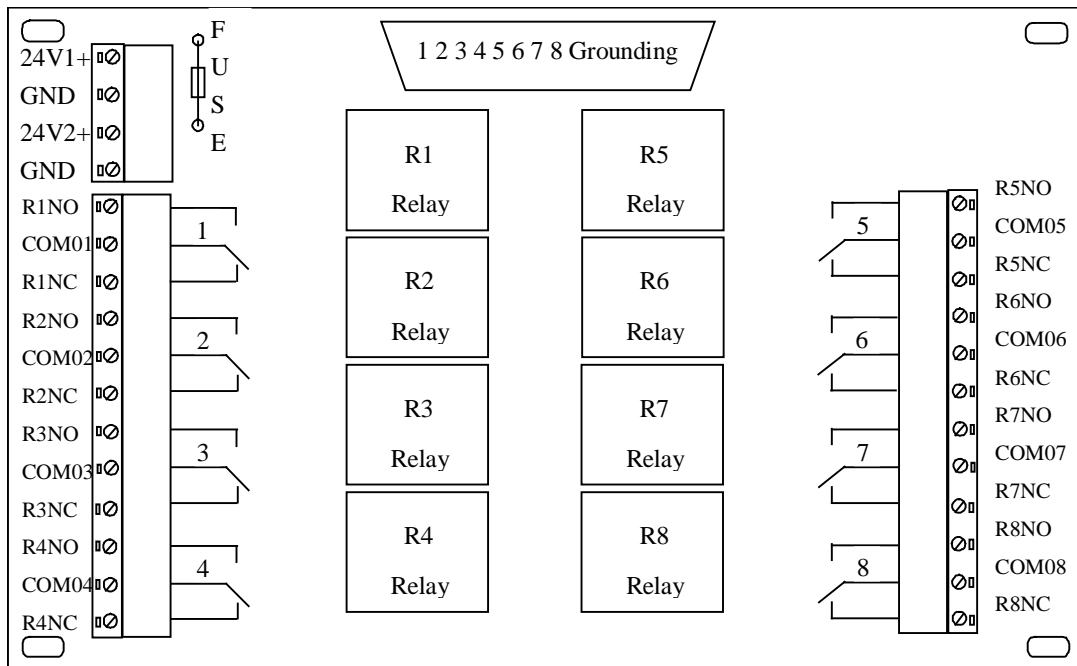
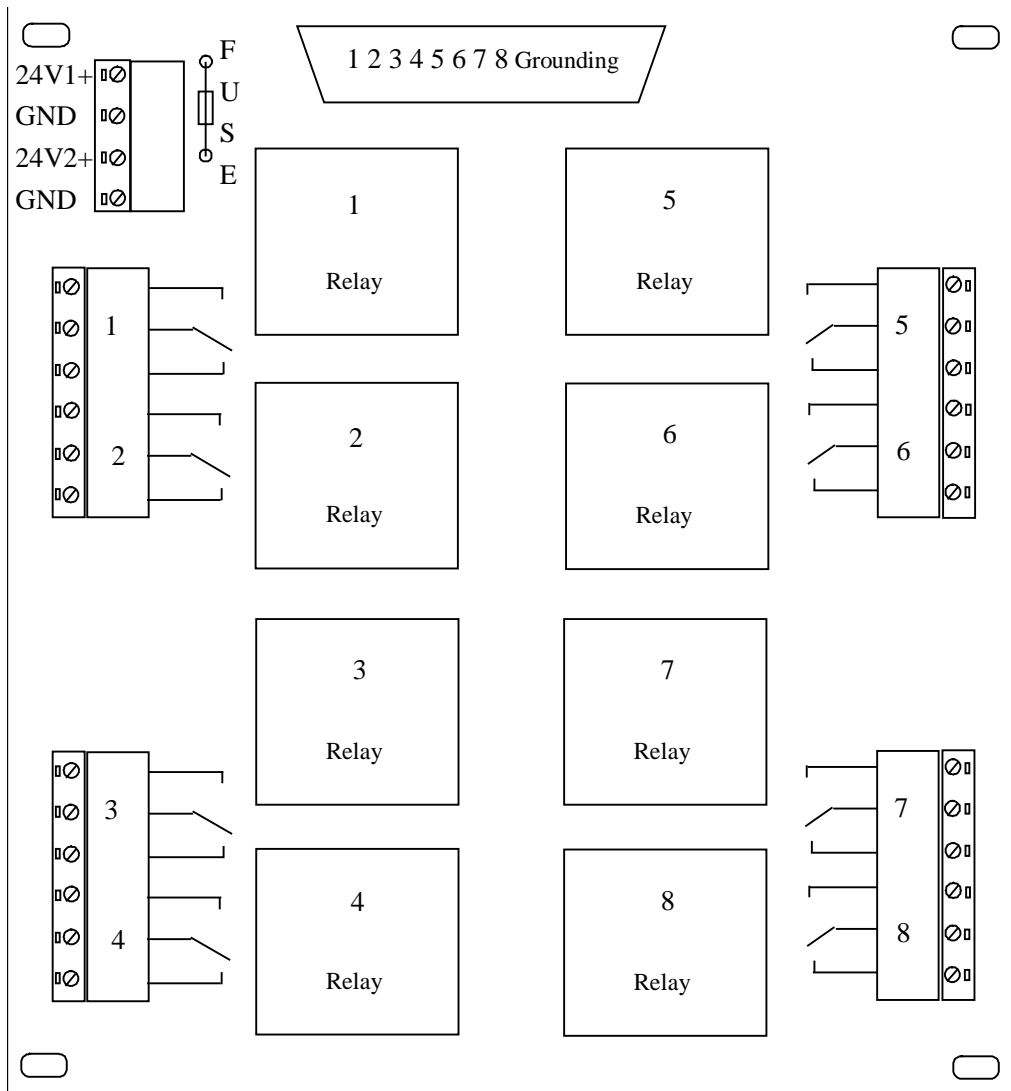

Figure 3-24 Relay Board

Description of relay board:

- 24V1+/24V2+: 2 circuits of 24VDC power supply
- GND: 24V power supply (grounding)
- FUSE: Changeable power fuse
- R1NO- R8NO: normally close end
- R1NC- R8NC: normally open end
- COM: common end
- 36P D type socket: 1-8 refer to relay R1-R8, two grounding ends connect with 24V power grounding.

Channel 1-8 corresponds to relay R1-R8.



Description of relay board:

- 24V1+/24V2+: 2 circuits of 24VDC power supply
 - GND: 24V power supply (grounding)
 - FUSE: Changeable power fuse
 - 36P D type socket: 1-8 refer to relay R1-R8, two grounding ends connect with 24V power grounding.
- Channel 1-8 corresponds to relay 1-8.

9 LN-09B Isolated SOE Module

Depending on the setting of SW2, LN09 module will be in SOE function when 1 and 3, 2 and 4 are connected respectively.

Main component arrangement of the module is as shown in Figure3-26.

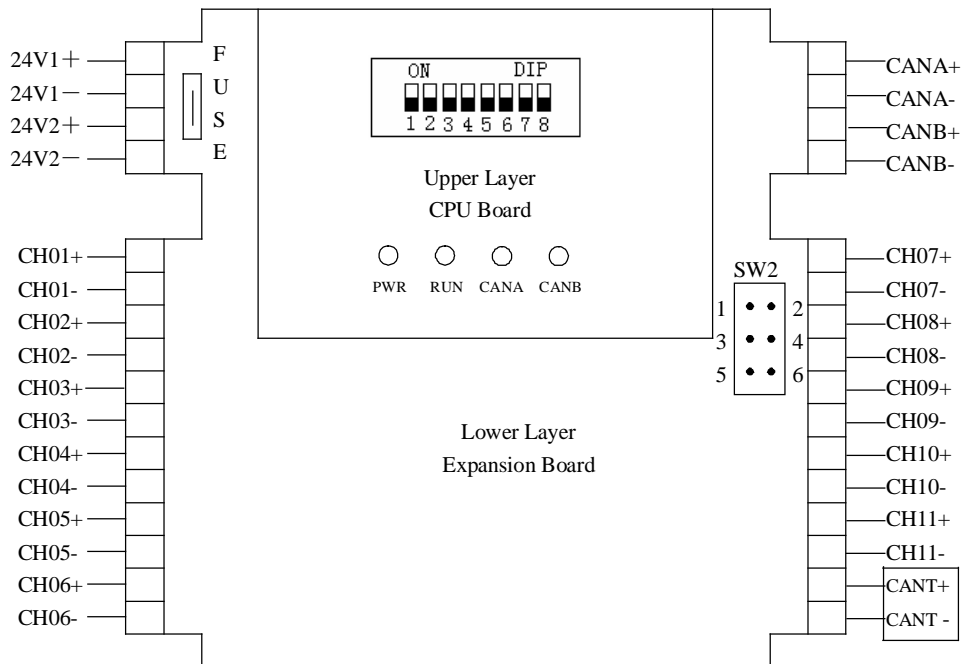

Figure3-26 LN09B module main component arrangement

(1) Principle

LN09 module is provided with 11 input channels. The input voltage or inactive contact signals are transmitted to the singlechip computer via the optoelectronic isolator after being processed at input end. The singlechip computer samples with an interval of 1 millisecond. After 20 times anti-dithering filtering, the SOE processing begins. Resolution of SOE is 1 millisecond. Both the rising and falling edges of digital & input are taken as events. The buffer size of SOE is 100 events. The SOE and digital real time information are transmitted to the upper computer via CAN communication interface.

**(2) Main Technical Parameters**

Module Type		LN-09B
Input Channel	Number of channel	11 channels
	Signal type	Dry contact
	Resolution	1ms
	Logic '0'level	>20V
	Logic '1'level	<15V
	Memory buffer	100 events
	Dithering eliminating period	20ms
	Scanning period	1ms
	System isolating voltage	1000Vrms
Synchronization	CAN interface	Cooperated with module LN-GPS, synchronization accuracy is 1ms
Communication	Number of interface	2, redundant for each other
	Baud Rate	500kbps/1000kbps/100kbps/20kbps
Power Supply	Power supply Redundancy	2, redundant for each other
	Voltage	24VDC±10%
	Power isolating voltage	1000VDC
	Power(MAX)	4W
Others	A quick-breaking general fuse is provided	
	Module address is set by DIP thumb wheel switches	
	Operating temperature: -10°C~60°C	

(3) Main Component Arrangement

Main component arrangement of LN09B isolated SOE module (shown in Figure3-26)

FUSE:	Changeable power fuse
SW1:	CAN Communication address and Baud Rate setting switch
PWR:	Power LED indicator
RUN:	Operation LED indicator
CANA:	CAN Communication LED indicator
CANB:	CANB Communication LED indicator
SW2:	CANC/CH12 switch jumper (it is digital input mode when SW2 jumper 3 and 5, 4 and 6 are connected; it is SOE mode when SW2 jumper 1 and 3, 2 and 4 are connected;)

Definition of wiring terminals:

24V1+, 24V2+:	Module power supply (DC24V) positive end
24V1-, 24V2-:	Module power supply (DC24V) negative end
CANA+:	to CANA Communication positive end
CANA-:	to CANA Communication negative end
CANB+:	to CANB Communication positive end
CANB-:	to CANB Communication negative end
CH01+~CH11+:	to digital input channel1~11 signal positive end
CH01-~CH11-:	to digital input channel1~11 signal negative end
CANT+~CANT-:	to GPS synchronization signal

10 LN-GPS Module

(1) Principle

The GPS synchronization module is provided with two CAN output synchronization channels, 4 RS-485 and 2 RS-232 serial communication synchronization channels. When the module works, it tracks GPS satellite to receive accurate time and position information and outputs the information via CAN and serial interfaces after being analyzed.

Principle diagram of LN-10B GPS module is as shown in Figure3-28.

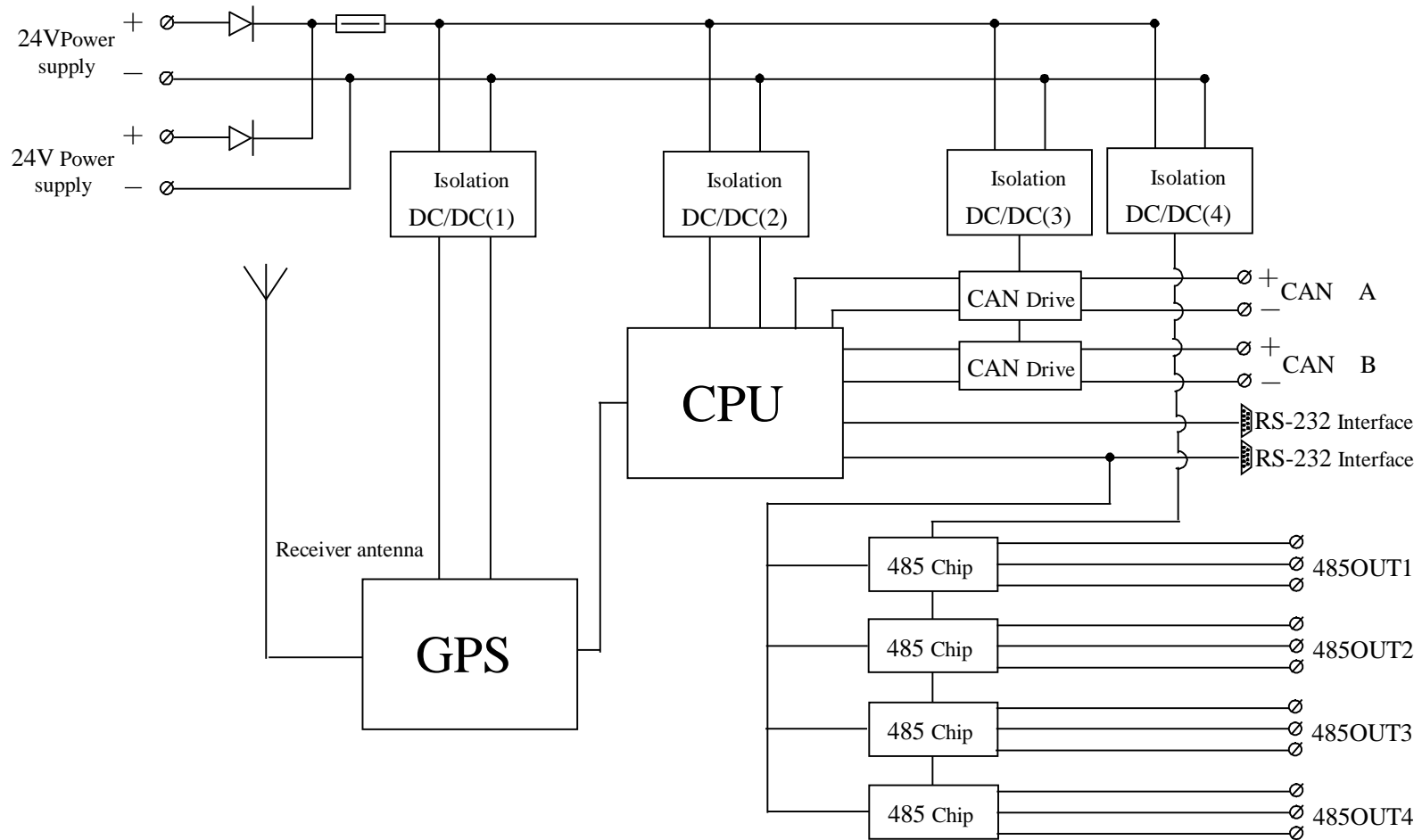

Figure 3-28 Principle diagram of GPS module

**(2) Main Technical Parameters**

Module Type		LN-GPS
CAN Output channel	Number of channel	2
	Signal type	CAN protocol 2.0A, Baud rate :20kbps, distance: 3.3km
	Synchronization accuracy	1ms
	Node quantity	60 modules/channels
	Synchronization interval	10s
	System isolating voltage	1000Vrms
RS232 Output channel	Number of channel	2
	Signal type	RS-232 protocol
	Synchronization accuracy	1ms
	Synchronization interval	3 min
RS485 Output channel	Number of channel	4
	Signal type	RS-485 protocol
	Synchronization accuracy	1ms
	Synchronization interval	3 min
Power Supply	Power Supply Redundancy	2 redundant power supplies
	Voltage	24VDC±10%
	Power isolating voltage	1000VDC
	Power(MAX)	4W
others	A quick-breaking general fuse is provided.	
	Operating temperature: -10℃~60℃	

(3) Main Component Arrangement

Main component arrangement of Module LN-10BGPS (shown in Figure3-29)

FUSE:	Changeable power fuse
PWR:	Power LED indicator
RUN:	Operation LED indicator
CANA:	CAN Communication LED indicator
CANB:	CANB Communication LED indicator

Definition of wiring terminals:

24V1+, 24V2+:	Module power supply (DC24V) positive end
24V1-, 24V2-:	Module power supply (DC24V) negative end
CANA+:	to CANA Communication positive end
CANA-:	to CANA Communication negative end
CANB+:	to CANB Communication positive end
CANB-:	to CANB Communication negative end
RS-485OUT1+~RS-485OUT4+:	485 interface positive end
RS-485OUT1-~RS-485OUT4-:	485 interface negative end
GND:	grounding end of module isolator
RS-232 interface 1~2:	2 signal interfaces of RS-232 9-pin serial port

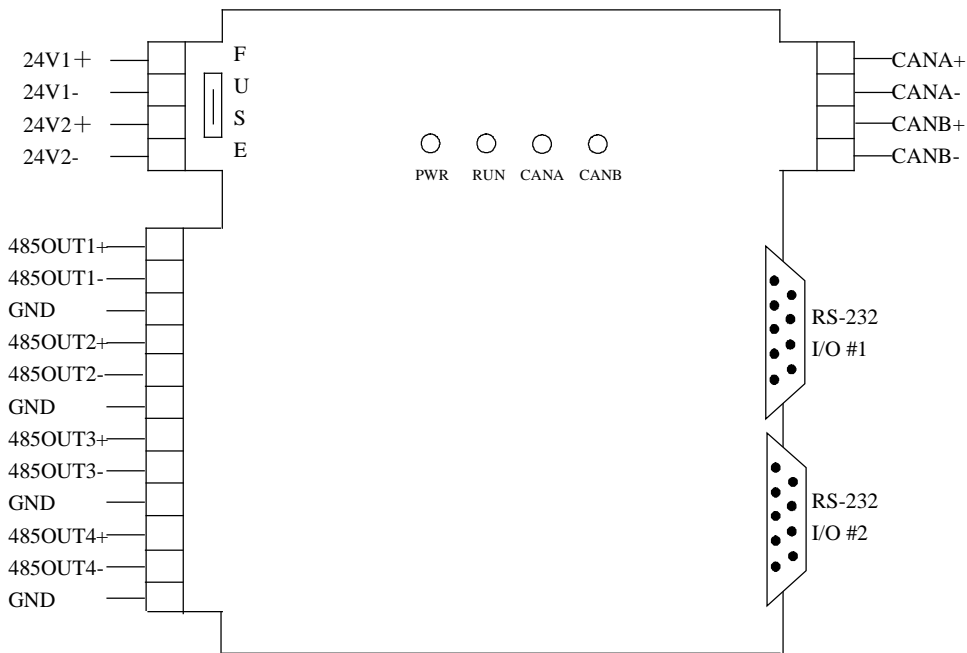
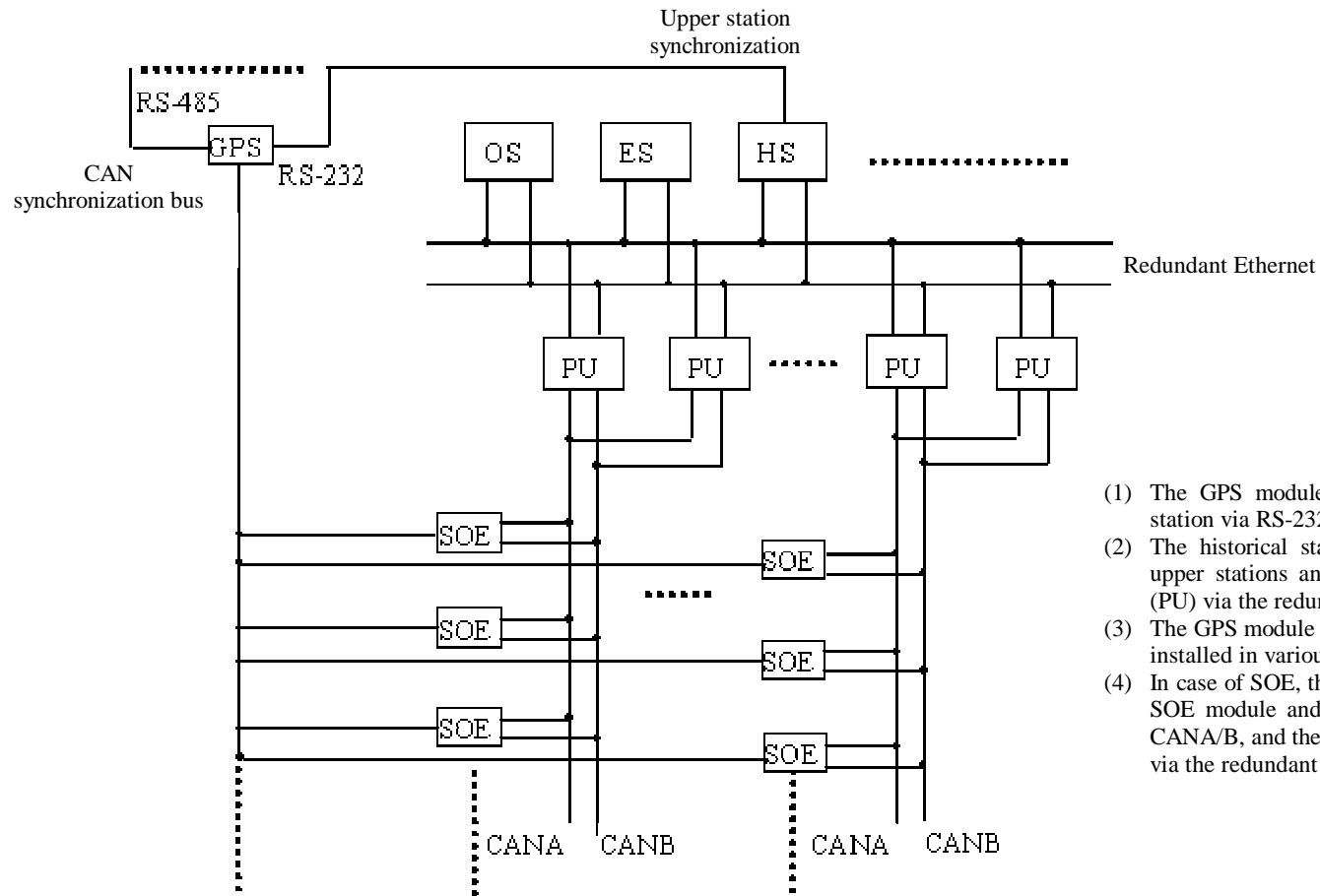

Figure 3-29 Main component arrangement of LN-10B module



Notes

- (1) The GPS module synchronizes the historical station via RS-232 or RS-485 interface;
- (2) The historical station synchronizes the other upper stations and all process control station (PU) via the redundant Ethernet;
- (3) The GPS module synchronizes all SOE (can be installed in various PU) modules via CAN bus;
- (4) In case of SOE, the SOE record is stored in the SOE module and sent to the PU via I/O bus CANA/B, and then be sent to the upper stations via the redundant Ethernet.

Attached Figure3.4 GPS synchronization network structure